

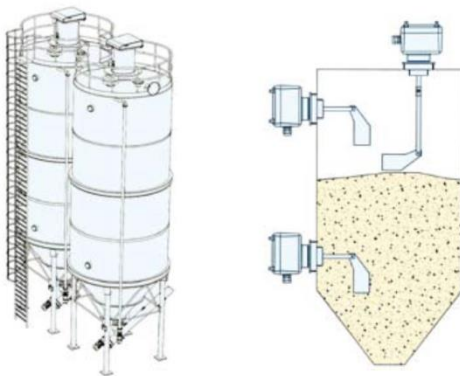

The TLS 110 and TLS 210 series motor level sensors are commonly used to determine the lower and upper positions of the level in areas such as Silo, Warehouse, etc., or intermediate values if desired.

The sensor which rotates 1 round per minute with low torque, stops with touching the material during scanning, and the contacts inside it change the position to indicate that the silo is empty or full.

With G1½" ve G2½" bconnections types, it can be mounted at different holes. The torque value can be adjusted in 3 different levels according to the material density.



- Robust Body
- ON / OFF level control for solids Cereal, Coral etc.
- Adjustable sensitivity in 3 different positions
- 220VAC or 24VDC models
- 2 different mounting dimensions

Technical Specifications

Output Signals	Relay Output ON / OFF control (Mikroswitch) AC max. 250V, 2A, 500W (cos=1) DC max. 300V, 2A, 60W
Supply Voltage	TLS 110 : 24VDC TLS 210 : 220VAC 50/80 Hz (Supply Voltages +10% / -15%)
Current Consumption (max)	TLS 110 : 25 mA @24VDC TLS 210 : 130 mA @220VAC
Precision	Traction sensitivity adjustable in 3 different positions
Rotation Speed	1 round per minute
Electrical Connection	1 x PG 13.5"
Delay Time	Approximately 1.3 seconds
Connection Type	G1½" ve G2½"
Working Pressure	0.8 bar max.
Working Temperature	-20°C ...+70°C
Material	Main Body Plastic, other components stainless steel
Protection Class	IP 65
Weight	1000 gr
Accessories	Pedal, mounting flange and optional extension shafts

Thanks to its compact and ergonomic structure, it is the most ideal level control solution for accurate and stable measurement without affecting from the environment conditions.

Main usage areas:

- SILOS
- WAREHOUSES
- PLASTIC GRANULAR TANKS etc. places

Order Details

Model No

T L S - 1 1 0 - 24 VDC

SUPPLY VOLTAGE

110 Series : 24VDC
210 Series : 220VAC 50/80 Hz

Package Included

1 pcs stainless metal body pedal
1 pcs metal mounting flange

Recommended Accessories

Shafts of 50 cm or 100 cm can be used for lengthening



Electrical Connection

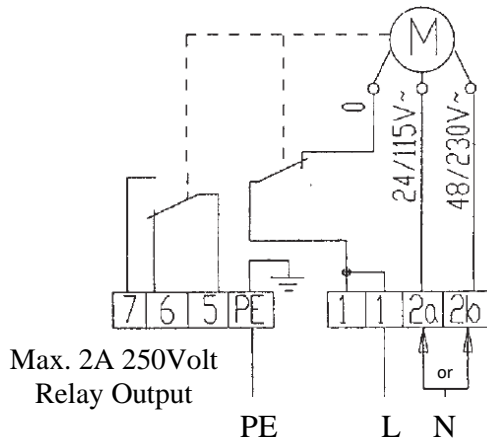

Connection for TLS 210 SERIES 220VAC model

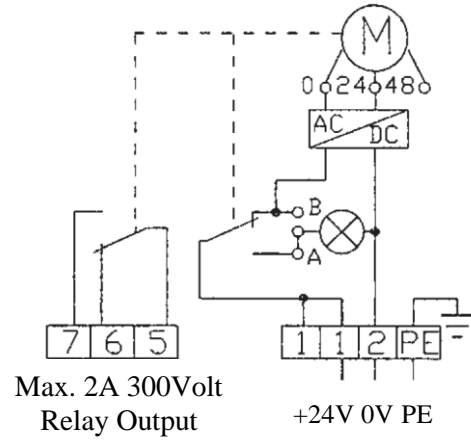

Connection for TLS 110 SERIES 24VDC

Mechanical Dimensions

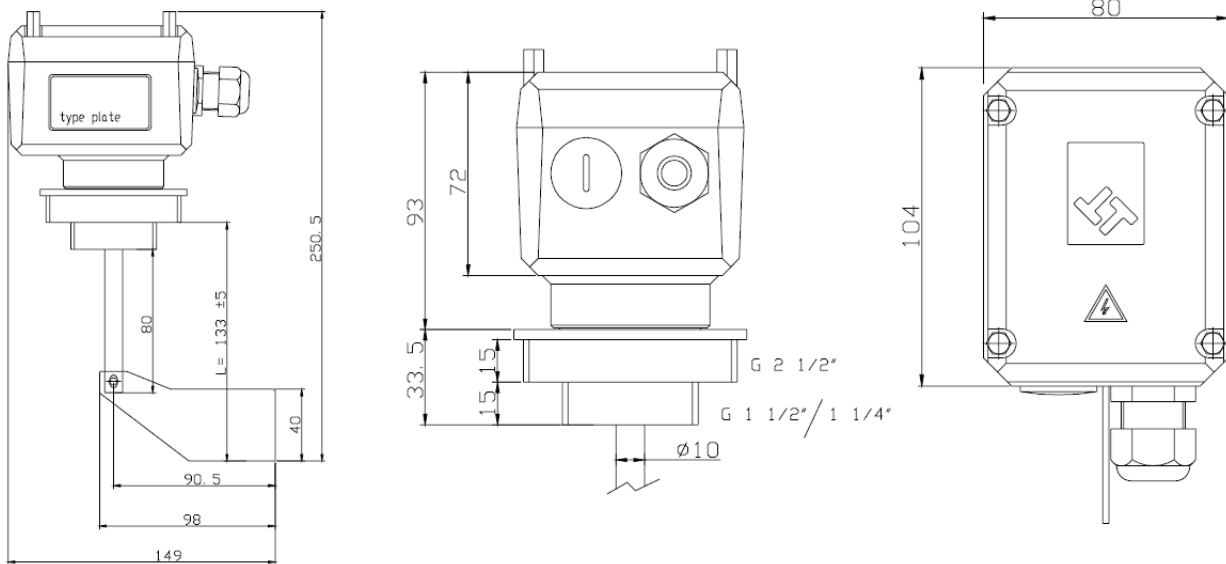

Mounting Shape

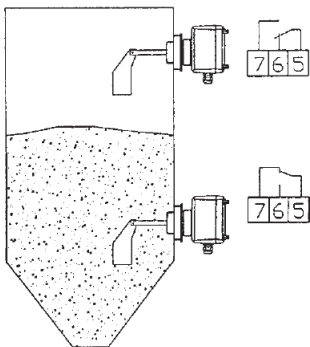

The most important points to be considered during installation are:

The sensor can be mounted horizontally or vertically.
While connecting, it should be turned clockwise.
The seal can be used to ensure sealing.
The cable gland must point downwards.

At the same time, it is possible to block the damage of substance coming from above, by adding a sheet plate on sensor.

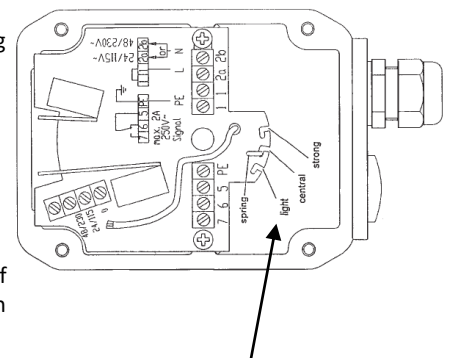

The sensitivity of the sensor can be adjusted in 3 different positions.

Atek Sensor Technology A.S.

Tuzla KOSB Organize Sanayi Bolgesi Melek Aras Bulvari No:67 PK:34956 Tuzla / İstanbul - TURKEY

Tel: +90 216 399 44 04

Fax: +90 216 399 44 02

www.ateksensor.com

info@ateksensor.com