

# DRAW WIRE ENCODER USER MANUAL

## AWE 210

### GENERAL INFORMATION

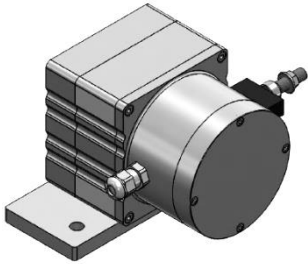

AWE 210 wire encoders convert linear motion into incremental digital pulses. Different measuring lengths from 1000 mm to 5000 mm are available. Optionally other stroke lengths, resolutions, cable lengths and socket connectors can be requested.

They make measurement by pulling and rewinding stainless steel wire. Usage is practical and usage area is quite wide. By connecting to a counter or position controller, they become a perfect system in high resolutions for position control in wood processing, marble machines, glass processing machines and other machines.

### WARNINGS

- The installation of the product is carried out by the customer who purchases the product, according to the wiring diagrams, installation information, etc. in this manual.
- Maintenance and repair should be done by the technicians authorized by the manufacturer firm.
- There must be minimum distance between the sensor and control unit. Avoid additions except the suitable connector unless it needs.
- Keep away the sensor cable from as high power energy cables, contactor, motor, switched power supplies, inductive and capacitive noisy supplies.
- Shielding edge of the sensor cable must be ground connected.
- Not to damage the sensor supply directions and voltage must be paid attention (For TTL sensor max. 5V, PP, HTL, HPL sensor max. 30V). Don't energize before all connections completed.
- Transport and storage should be at their original packaging and an ambient temperature of -25°C / +85°C in such a way that they will not be exposed to dust, humidity, impact, vibration, falling or water.
- Chemicals such as alcohol, thinner etc. should not be used for cleaning the product. The product should be wiped with a damp cloth.
- The product may be damaged and may become unusable if used outside of the specifications in the user manual.
- The product will be out of warranty if used outside of the specifications in the user manual and opened or repaired other than authorized services.

### ELECTRICAL CONNECTIONS

In the left tablet he cable colors of sensors output signals are given. If the control circuit is suitable in the Line Driver sensors of the not output signals (/A, /B, /Z) have to be added to the system. If it is not suitable /A, /B, /Z signal cables must be fixed as insulated separately. Don't forget that these edges have electricity too.

Never make or undo electrical connections to the encoder when voltage is applied, otherwise this may result in damage to devices.

SIGNAL	CABLE COLOR
+V	Red
0V	Black
A	Yellow
/A	Blue
B	Green
/B	White
Z	Pink
/Z	Grey
EARTH	Silver

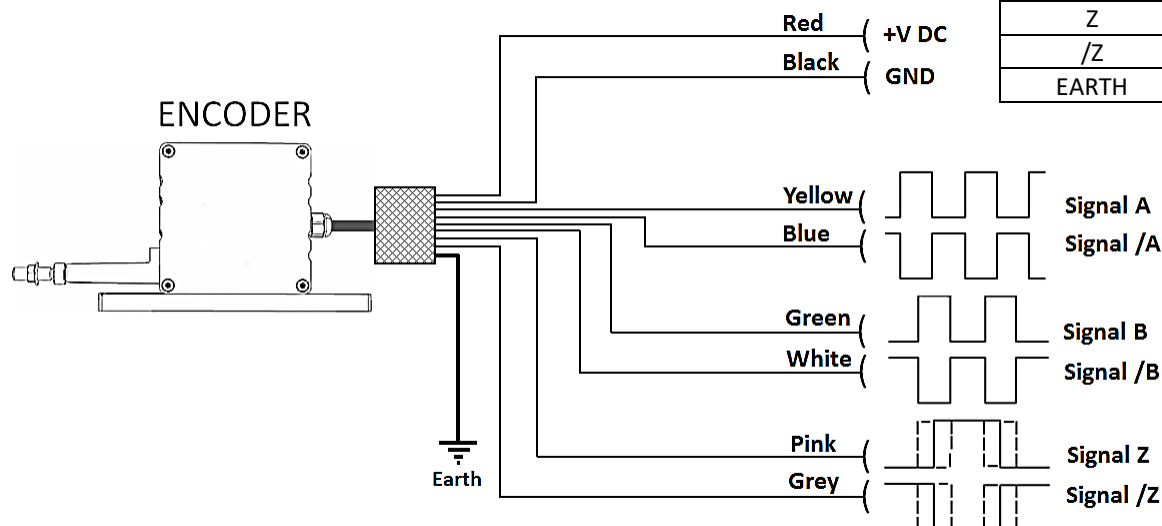

### M12 CONNECTOR-PIN CONNECTIONS (8 PINS)

SIGNAL	CABLE COLOR	PIN NO
A	Yellow	1
B	Green	2
+V	Red	3
0V	Black	4
Z	Pink	5
/A	Blue	6
/B	White	7
/Z	Grey	8

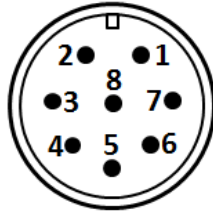

### M12 CONNECTOR-PIN CONNECTIONS (5 PINS)

SIGNAL	CABLE COLOR	PIN NO
A	Yellow	1
B	Green	2
+V	Red	3
0V	Black	4
Z	Pink	5

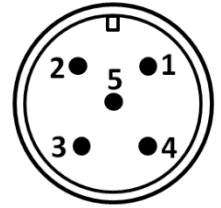

### M16 CONNECTOR-PIN CONNECTIONS

SIGNAL	CABLE COLOR	PIN NO
A	Yellow	1
/B	White	2
+V	Red	3
0V	Black	4
/A	Blue	5
B	Green	6
/Z	Grey	7
Z	Pink	8

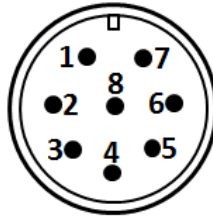

### M23 CONNECTOR-PIN CONNECTIONS

SIGNAL	CABLE COLOR	PIN NO
/B	White	1
+V	Red	2
Z	Pink	3
/Z	Grey	4
A	Yellow	5
/A	Blue	6
-	-	7
B	Green	8
Earth	Silver	9
0V	Black	10
0V	Black	11
+V	Red	12

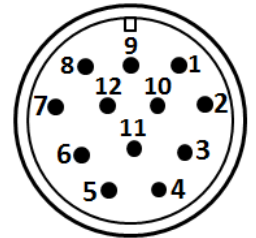

## MECHANICAL MOUNTING

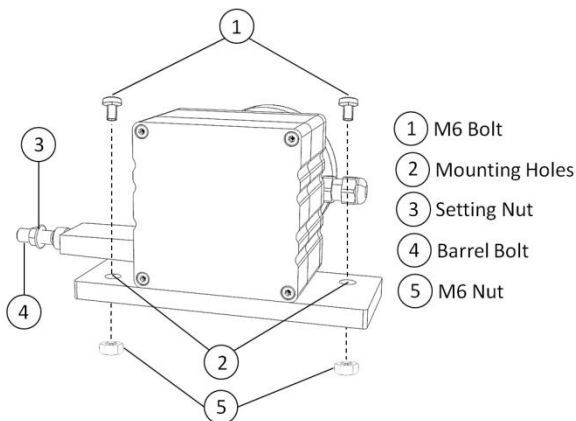

1- The product should be mounted to the relevant area with 2 units M6 bolts(1) and nuts(5) from the mounting holes (2) according to the mounting directions shown on page 3.

2- The encoder wire should be pulled towards the position to be connected with the barrel bolt (4).

3- The encoder wire should be mounted on the device to be connected by using the setting nut (3).

## DIMENSIONS

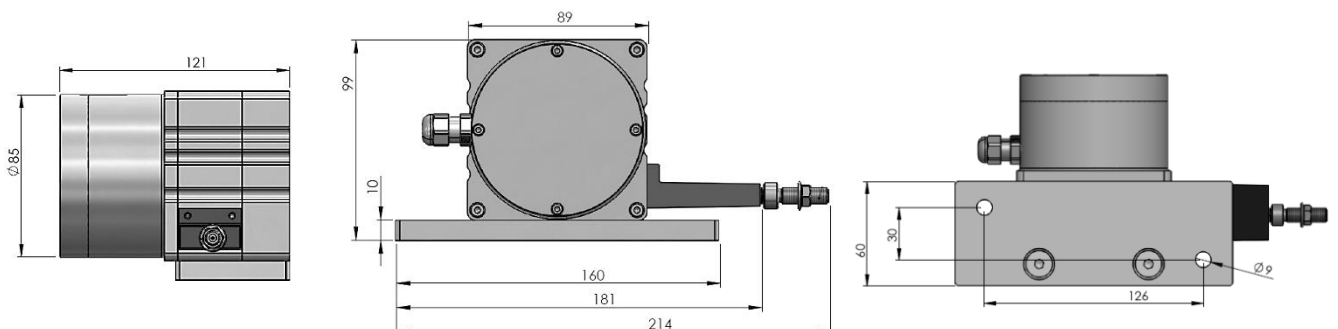

## TECHNICAL SPECIFICATIONS

<b>*Stroke (measuring) length</b>	Different measuring lengths from 1000 mm to 5000 mm		<b>Required Force</b>	10 N
			<b>Accuracy</b>	±0.25% FS
<b>*Resolution</b>	pulse/mm	mm/edge	<b>Operating Temperature</b>	-25°C ... +85 °C
	5 pulses/mm	0.05 mm		
<b>*Supply Voltage</b>	5...30V DC ±20%		<b>Relative Humidity</b>	%95
<b>*Output Signals</b>	A,B,Z (standard) A,B A,/A,B,/B A,/A,B,/B,Z,/Z		<b>Materials</b>	Housing: Aluminum/steel /ABS plastic
				Measuring Wire: Stainless steel (0.5mm or 1mm)
<b>Measuring Type</b>	Optic		<b>*Connection cable length</b>	3m (standard), 5m, 10m
<b>Maximum Speed</b>	2 m/s		<b>IP Protection Class</b>	IP53
<b>Maximum Output Current</b>	60 mA (per channel)		<b>Weight</b>	≈1900 gr

**Note:** The technical specifications indicated by (\*) vary according to the selected model. The detailed code table is shown on page 4.

## MOUNTING AND USAGE WARNINGS

**1. Never release the wire after pulling. Otherwise, the coil spring will be damaged.**

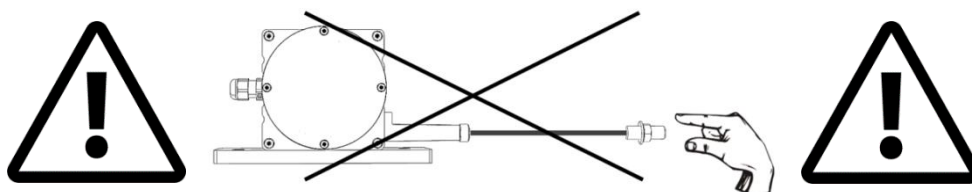

**2. Mount the sensor according to the mounting directions shown below.**

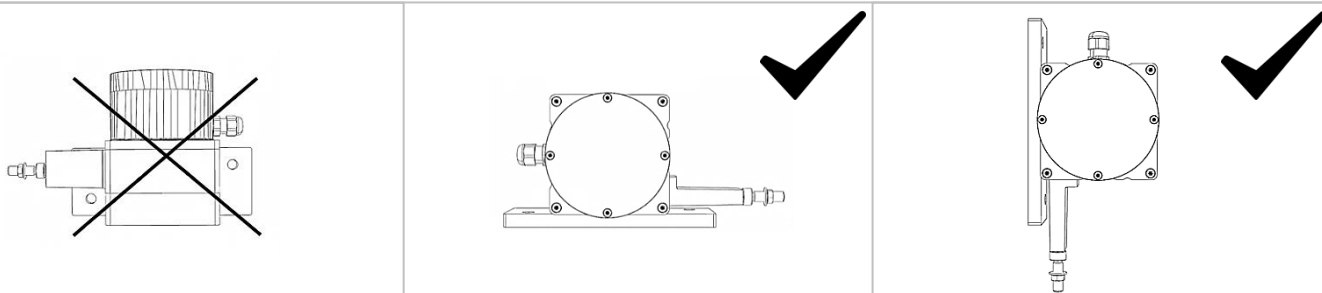

**3. If there is a trickle of water (like a rain), the wire outlet must not be a drip of water upstream. If needed please use guide rollers.**

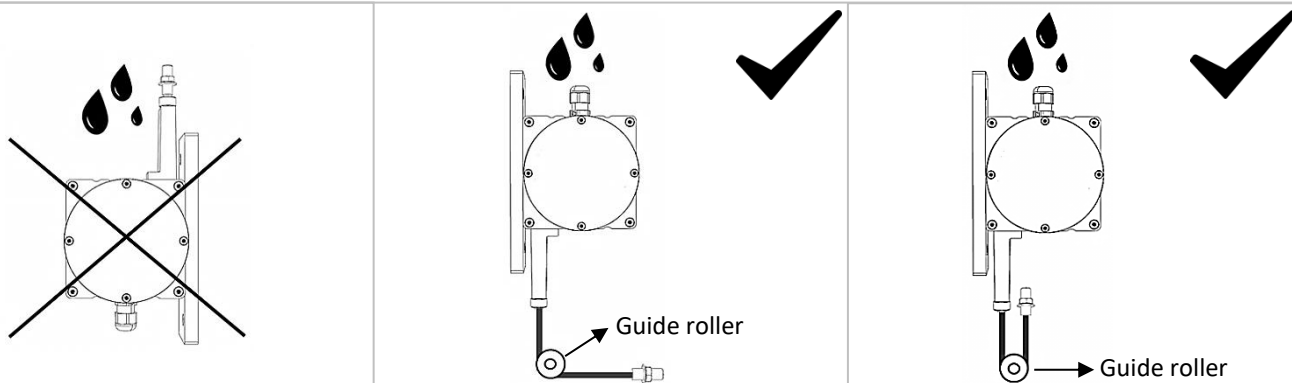

**4. The wire should not be pulled in angular. If needed, please use guide rollers.**

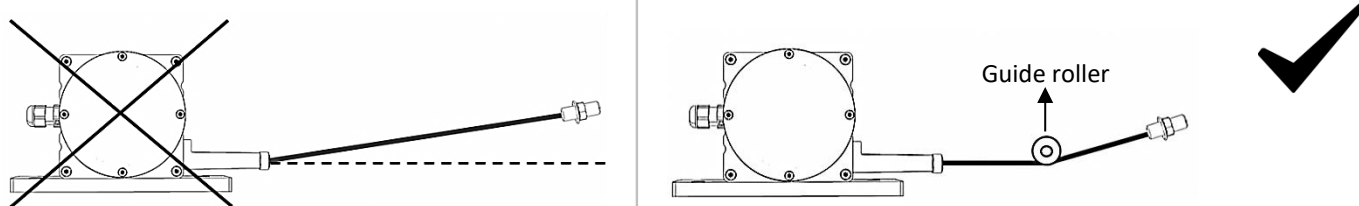

**Important Note(!):** Failure to comply with these recommendations, the malfunctions that may occur will not be under the warranty.

## BOX CONTENTS

Product	Description
<b>AWE 210</b>	Draw Wire Encoder
<b>User Manual</b>	1 pcs

## PRODUCT CODE TABLE

Model	Stroke Length *	Output Signals
AWE 210	Different measuring lengths from 1000 mm to 5000 mm	2 (A,B) 3 (A,B,Z) (standard) 4 (A,/A,B,/B) 6 (A,/A,B,/B,Z,/Z)
<b>AWE 210</b>	<b>XX</b>	<b>XXX</b>
	<b>XXX</b>	<b>X</b>
		<b>XX</b>
Resolution*	Supply and Output	Electrical Connection*
<b>02</b> : 0.2 mm/pulse	<b>PP</b> : 10...30 VDC Supply : 10...30VDC Output <b>TTL</b> : 5 VDC Supply : 5 VDC TTL RS422 Line Driver Output <b>HTL</b> : 10...30 VDC Supply : 5 VDC TTL RS422 Line Driver Output <b>HPL</b> : 5...30 VDC Supply (standard) : 5...30 VDC Push-Pull Output	<b>3M</b> : 3m (standard) <b>5M</b> : 5m <b>10M</b> : 10m <b>S13</b> : M12 5 Pin Male Socket <b>S16</b> : M16 8 Pin Male Socket <b>S23</b> : M23 12 Pin Male Socket

(\* ) Please contact for other (customized) options.

### Manufacturer Firm's and Authorized Service's Title, Address Details

**Manufacturer Firm:** ATEK ELEKTRONİK SENSÖR TEKNOLOJİLERİ SANAYİ VE TİCARET A.Ş.

**Address:** Gebze OSB, 800. Sokak, No:814 Gebze/KOCAELİ/TÜRKİYE

**TEL:** +90 262 673 76 00 **FAX:** +90 262 673 76 08

**Web:** [www.ateksensor.com](http://www.ateksensor.com) **E-mail:** info@ateksensor.com



**Disposal of Packagings:** Packaging materials consist of recyclable materials. For providing recycling, please dispose waste packagings to collecting points of authorized recycling facilities.

**Disposal of E-Waste:** This device is in conformity with WEEE Directive and consists of recyclable materials. This product should not be disposed with general waste for preventing negative effects on environment and human health. This product should be disposed to collecting points of authorized recycling facilities. Further information can be reached from authorized unit.