

INC-110

INCLINOMETER / TILT SENSOR

CANopen

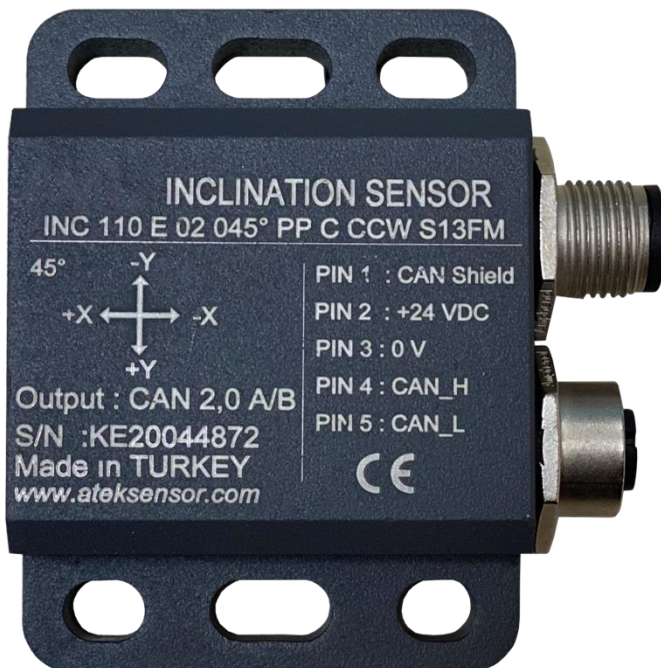

USER

MANUAL

INDEX

1. TECHNICAL PROPERTIES.....	2
2. CONNECTIONS.....	3
2.1. DIMENSIONS.....	3
2.2. ELECTRICAL CONNECTIONS.....	4
3. CONFIGURATIONS.....	5
3.1. LSS CONFIGURATION.....	5
3.2. SDO CONFIGURATION.....	7
4. OBJECT DICTIONARY	8
4.1. MANUFACTURER SPECIFIC OBJECTS.....	8
4.2. STANDARDIZED DEVICE PROFILE.....	10
4.3. COMMUNICATION PROFILE AREA.....	11
4.4. MANUFACTURER SPECIFIC EMERGENCY OBJECTS.....	13



INC 110 SERIES INCLINOMETERS

- $\pm 90^\circ$ dual axis measurement range or 0-360° single axis measurement range option
- 4-20 mA, 0-10V or CANopen signal output option
- Compensated axis sensitivity
- High Sensitivity : $\pm 0.2^\circ$
- Ability to specify 0° point
- Easy installation
- IP67 protection class
- Small and robust housing
- Compact structure

Tilt Sensors are sensors that measure the inclination of all objects standing in the plane in the (+) and (-) directions of the X and Y axes. They have $\pm 90^\circ$ dual axis and 0-360° single axis measurement range. These sensors with CANopen signal output option can measure up to $\pm 0.2^\circ$ accuracy. Thanks to its compensated axis sensitivity, the effect of the axes on each other is minimized.

These sensors, especially used in machine and crane industries, can operate in outdoor environments with their high IP protection classes.

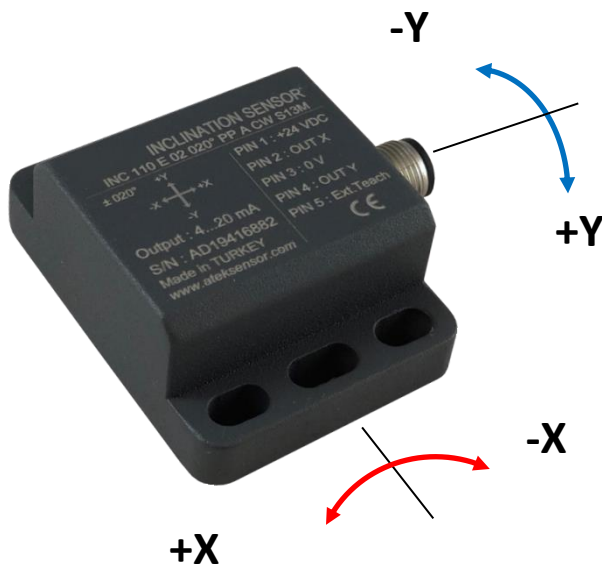

CANopen®

Sectors Used

- Crane Systems
- Fire Trucks
- Vehicle mounted equipments
- Machinery and Automation Applications
- Shipping
- Robotic Systems

1. TECHNICAL PROPERTIES

GENERAL PROPERTIES

Measurement Range	Single axis: 360°, Dual axis: ±90°
Supply Voltage	12...24VDC
Measurement Axes	X , XY
Output Signal	CANopen
Accuracy	±0,2°
Resolution	0.05°
Response Frequency	10 Hz.
Reaction Time	500 ms (Time required for sensor output to reach 90% of full scale)
Protection Class	IP 67
Relative Humidity	%10 and %90
Operating Temperature	-30...+70 °C
Electrical Connection	M12 5 pin (male) and M12 5 pin (female) socket
Body Material	Aluminium
Weight	140 grams

CANopen PROPERTIES

Communication profile	CiA 301
Device Type	CANopen, CiA DS410
Node ID	Between 1 and 127, it can be adjusted with LSS or SDO
Baud Rate	10 kBit/s, 20 kBit/s, 50 kBit/s, 100 kBit/s, 125 kBit/s, 250 kBit/s, 500 kBit/s, 800 kBit/s, 1 Mbit/s
PDO Data Rate	100 ms
Error Control	Heartbeat, Emergency Message
PDO	1 Tx PDO
PDO Modes	Event/Time triggered, Synch/Asynch
SDO	1 server
Position Information	Object Dictionary 6004
Termination Resistance	Optional, specify at the order stage.

2.CONNECTIONS

2.1 Dimensions

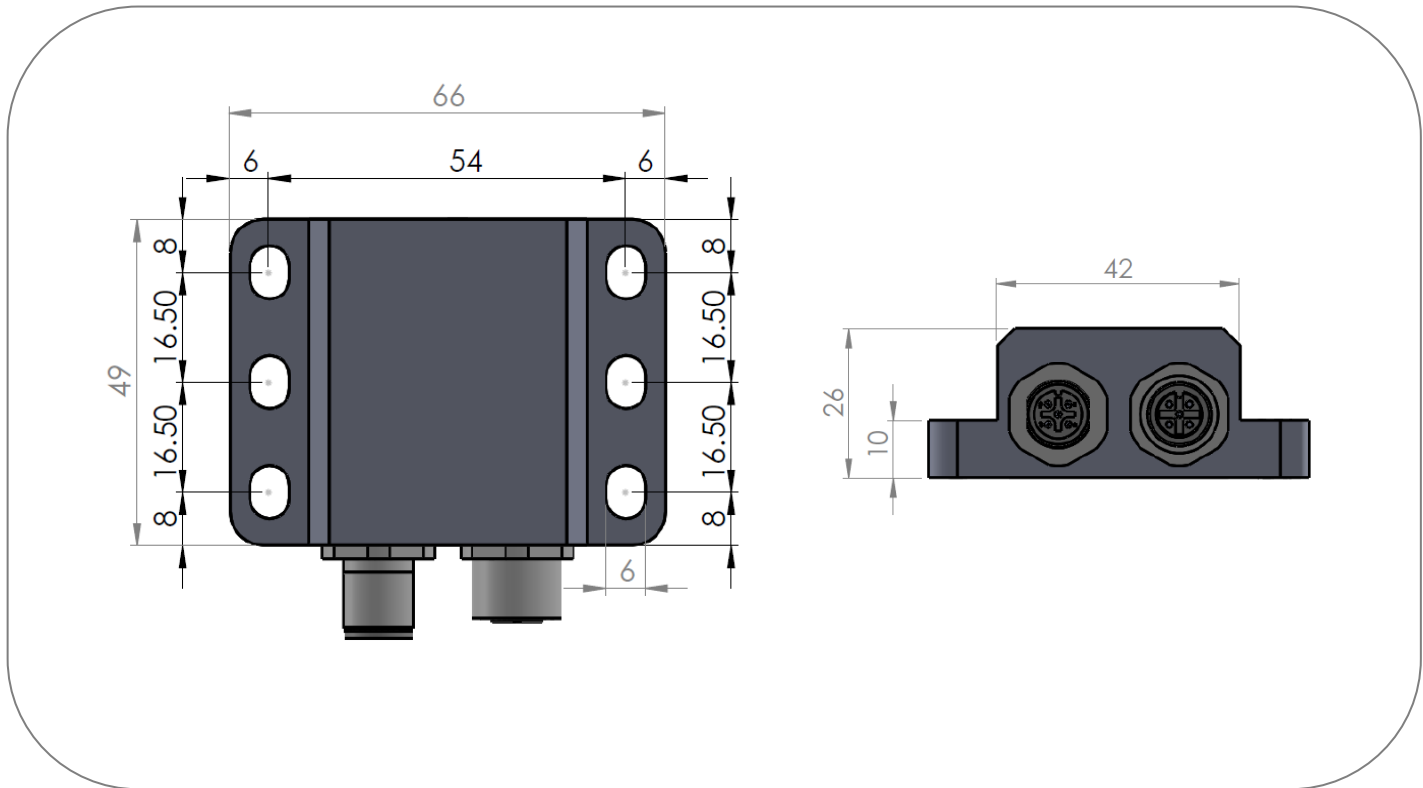

2.2 Electrical Connections

Signal	M12 Socket	Cable
CAN_SHIELD	Pin 1	Mesh
U+ (12..24VDC)	Pin 2	Red
GND (0V)	Pin 3	Black
CAN_H	Pin 4	Yellow
CAN_L	Pin 5	Green

* CANopen models have 2 outputs. 1 pcs M12 5 pin male and 1 pcs M12 5 pin female sockets are used as standard.

* Different socket models can be requested optionally.

M12 5 Pin Female Socket

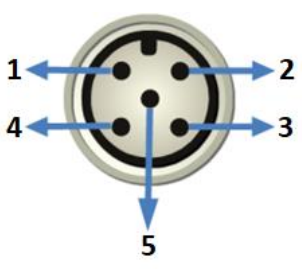

M12 5 Pin Male Socket

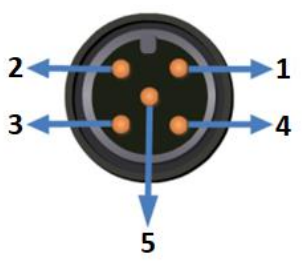

ORDER CODE

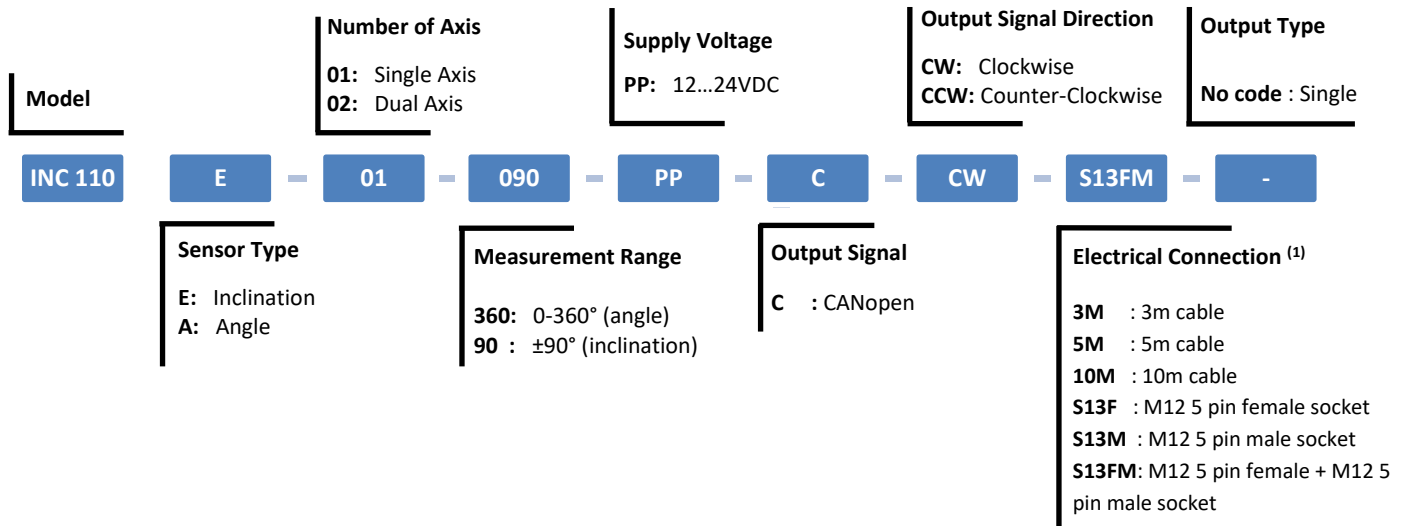

(1) The product can be requested with cable or socket.

As standard;

For CANopen output models, 1 pcs M12 5 pin female + 1 pcs M12 5 pin male socket (S13FM) is used.

However, different socket combinations may be requested as in the examples below.

Please contact us for any other socket model other than M12.

Sample Code 1: INC110-E-02-45-PP-C-CCW-S13FM

INC 110 series, inclination, dual axis, ±45° measurement, 12-24VDC supply, CANopen output, counter-clockwise, 1 pcs M12 5 pin female + 1 pcs M12 5 pin male socket

Sample Code 2: INC110-A-02-90-PP-C-CCW-S13M

INC 110 series, angle, dual axis, ±90° measurement, 12-24VDC supply, CANopen output, counter-clockwise, 2 pcs M12 5 pin male sockets

3.INTERFACE CONFIGURATION

Unless specified in the order, 'Default Node ID:1'

Baud Rate: 500 kBit/s These two parameters can be adjusted via 2 protocols:

1. LSS protocol
2. SDO protocol

3.1 LSS Protocol Configuration

To change Node ID and Baud Rate via LSS protocol;

- No other device should be connected to the corresponding CAN network other than LSS master device and LSS slave device whose NODE ID and Baud Rate will be changed.
 - LSS Slave's Baud Rate should be known before the configuration. (Default Baud Rate is 500 kBit/s.)
 - Baud Rate's of both LSS Master and Slave should be same.
 - Example communications via LSS protocol are given in the Table 3 and 4.
- Baud Rate parameter is set according to the table below.

Baud Rate	10 kBit/s	20 kBit/s	50 kBit/s	100 kBit/s	125 kBit/s	250 kBit/s	500 kBit/s	800 kBit/s	1 Mbit/s
Parameter Value	8	7	6	5	4	3	2	1	0

WARNING: All changes are saved automatically and will be active after any reboot.

Message	Details	COB-ID	Data (Hex)
Lss Master Request	Switch Mode Global-Configuration Mode	0x7E5	04 01 00 00 00 00 00 00
Lss Master Request	Inquire Identity – Vendor ID	0x7E5	5A 00 00 00 00 00 00 00
Lss Slave Response	Inquire Identity – Vendor ID : 0x00000000	0x7E4	5A 00 00 00 00 00 00 00
Lss Master Request	Inquire Identity – Product Code	0x7E5	5B 00 00 00 00 00 00 00
Lss Slave Response	Inquire Identity – Product Code : 0x00000000	0x7E4	5B 00 00 00 00 00 00 00
Lss Master Request	Inquire Identity – Revision Nr.	0x7E5	5C 00 00 00 00 00 00 00
Lss Slave Response	Inquire Identity – Revision Nr. : 0x00000000	0x7E4	5C 00 00 00 00 00 00 00
Lss Master Request	Inquire Identity – Serial Nr.	0x7E5	5D 00 00 00 00 00 00 00
Lss Slave Response	Inquire Identity – Serial Nr. : 0x00000000	0x7E4	5D 00 00 00 00 00 00 00
Lss Master Request	Inquire Node ID	0x7E5	5E 00 00 00 00 00 00 00
Lss Slave Response	Inquire Node ID – NID : 0x01	0x7E4	5E 01 00 00 00 00 00 00
Lss Master Request	Switch Mode Global-Operation Mode	0x7E5	04 00 00 00 00 00 00 00

Table 3. LSS auto detect

Message	Details	COB-ID	Data (Hex)
Lss Master Request	Switch Mode Selective – Vendor ID : 0x00000000	0x7E5	40 00 00 00 00 00 00 00
Lss Master Request	Switch Mode Selective – Product Code : 0x00000000	0x7E5	41 00 00 00 00 00 00 00
Lss Master Request	Switch Mode Selective – Revision Nr. :0x00000000	0x7E5	42 00 00 00 00 00 00 00
Lss Master Request	Switch Mode Selective – Serial Nr. : 0x00000000	0x7E5	43 00 00 00 00 00 00 00
Lss Slave Response	Switch Mode Selective Response	0x7E4	44 00 00 00 00 00 00 00
Lss Master Request	Configure Bit Timing Parameters – Table Selector : 0 , Table Index : 4	0x7E5	13 00 04 00 00 00 00 00
Lss Slave Response	Configure Bit Timing Parameters – Success	0x7E4	13 00 00 00 00 00 00 00
Lss Master Request	Switch Mode Global-Operation Mode	0x7E5	04 00 00 00 00 00 00 00
Lss Master Request	Switch Mode Global-Configuration Mode	0x7E5	04 01 00 00 00 00 00 00
Lss Master Request	Activate Bit Timing Parameters – Switch Delay: 100ms	0x7E5	15 64 00 00 00 00 00 00
Lss Master Request	Switch Mode Global-Operation Mode	0x7E5	04 00 00 00 00 00 00 00
Lss Master Request	Switch Mode Selective – Vendor ID : 0x00000000	0x7E5	40 00 00 00 00 00 00 00
Lss Master Request	Switch Mode Selective – Product Code : 0x00000000	0x7E5	41 00 00 00 00 00 00 00
Lss Master Request	Switch Mode Selective – Revision Nr. : 0x00000000	0x7E5	42 00 00 00 00 00 00 00
Lss Master Request	Switch Mode Selective – Serial Nr.: 0x00000000	0x7E5	43 00 00 00 00 00 00 00
Lss Slave Response	Switch Mode Selective Response	0x7E4	44 00 00 00 00 00 00 00
Lss Master Request	Configure Node ID – NID : 0x02	0x7E5	11 02 00 00 00 00 00 00
Lss Slave Response	Configure Node ID - Success	0x7E4	11 00 00 00 00 00 00 00
Lss Master Request	Store Configuration	0x7E5	17 00 00 00 00 00 00 00
Lss Slave Response	Store Configuration - Success	0x7E4	17 00 00 00 00 00 00 00
Lss Master Request	Switch Mode Global-Operation Mode	0x7E5	04 00 00 00 00 00 00 00
Reset	Reset All Nodes	0x000	81 00

Table 4. LSS configuration of NODE ID and Baud Rate

3.2 SDO Configuration

To change Node ID and Baud Rate via SDO protocol;

- LSS Slave's Baud Rate should be known before the configuration. (Default Baud Rate is 500 kBit/s.)
- Baud Rate's of all devices in the network should be same, and NODE ID's of all devices should be different.

NODE ID Configuration: NODE ID parameter is at Object Dictionary Index:3001 sub-index:0

Please change this parameter in order to change NODE ID.

Example shown below is to change NODE ID from 1 to 5.

Message	Node	COB-ID	Data (Hex)
SDO Download Request	0x01	0x601 (0x600 + Node Id)	2F 01 30 00 Node ID 00 00 00
SDO Download Response	0x01	0x581 (0x580 + Node Id)	60 01 30 00 00 00 00 00

Table 5. NODE ID configuration via SDO

Baud Rate configuration: Baud Rate parameter is at Object Dictionary Index: 3000 sub-index : 0

Baud rate parameter is set according to the table below.

Baud Rate	10 kBit/s	20 kBit/s	50 kBit/s	100 kBit/s	125 kBit/s	250 kBit/s	500 kBit/s	800 kBit/s	1 Mbit/s
Parameter Value	8	7	6	5	4	3	2	1	0

Example shown below is to set Baud Rate to 100 kBit/s.

Message	Node	COB-ID	Data (Hex)
SDO Download Request	0x01	0x601 (0x600 + Baud Rate)	2F 00 30 00 Baud Rate 00 00 00
SDO Download Response	0x01	0x581 (0x581 + Baud Rate)	60 00 30 00 00 00 00 00

Table 6. Baud Rate configuration via SDO

WARNING: All changes are saved automatically and will be active after any reboot.

4. OBJECT DICTIONARY

4.1 Manufacturer Specific Objects

Internal Temperature

Index	Sub Index	Name	Type	Value	Access	Save	Comment
0x2700	0x00	Internal Temperature	Integer 8		Read Only	No	1 unit value is 1 ° C.

Internal Temperature Monitoring

Index	Sub Index	Name	Type	Value	Access	Save	Comment
0x2701	0x00	Number of Entries	Unsigned 8	3	Read Only	No	
	0x01	Enable	Unsigned 8	0	Read/Write	Yes	
	0x02	Low Limit	Integer 8	-35	Read/Write	Yes	
	0x03	High Limit	Integer 8	80	Read/Write	Yes	

Baud Rate Setting

Index	Sub Index	Name	Type	Value	Access	Save	Comment
0x3000	0x00	Baud Rate Setting	Unsigned 8	2	Read/Write	Yes	

NODE ID Setting

Index	Sub Index	Name	Type	Value	Access	Save	Comment
0x3001	0x00	NODE ID Setting	Unsigned 8	1	Read/Write	Yes	

Auto Operational

Index	Sub Index	Name	Type	Value	Access	Save	Comment
0x3002	0x00	Auto Operational	Unsigned 8	0	Read/Write	Yes	If the value is 1, it switches to operational mode at startup.

Sequential Node Id

Index	Sub Index	Name	Type	Value	Access	Save	Comment
0x3005	0x00	Sequential Node Id	Unsigned 8		Write Only	No	

Unique ID

Index	Sub Index	Name	Type	Value	Access	Save	Comment
0x3010	0x00	Number of Entries	Unsigned 8	4	Read Only	No	
	0x01	Unique ID 1	Unsigned 32		Read Only	No	
	0x02	Unique ID 2	Unsigned 32		Read Only	No	
	0x03	Unique ID 3	Unsigned 32		Read Only	No	
	0x04	Unique ID 4	Unsigned 32		Read Only	No	

Acceleration

Index	Sub Index	Name	Type	Value	Access	Save	Comment
0x4020	0x00	Number of Entries	Unsigned 8	3	Read Only	No	
	0x01	Axis X	Integer 16		Read Only	No	
	0x02	Axis Y	Integer 16		Read Only	No	
	0x03	Axis Z	Integer 16		Read Only	No	

Internal Temperature Monitoring : It gives an emergency message when Low Limit and High Limit values are exceeded.

Sequential Node Id : In redundant devices, if both nodes receive the same id numbers, they will receive the value entered here sequentially. For example ; If 5 is entered, they are 5 and 6.

Note : For emergency messages, see section 4.4.

Slope Range

Index	Sub Index	Name	Type	Value	Access	Save	Comment
0x4500	0x00	Number of Entries	Unsigned 8	10	Read Only	No	The operating scale is set with the values entered in the min, max sub indexes. For example; If Xmin: -60, Xmax: 60 is entered, the X axis operates $\pm 60^\circ$. The enable sub indices must be 1 for the feature to be active. Enable Emergency sub indexes should be 1 if an emergency message is requested when the entered values are out of range.
	0x01	X min	Integer 16		Read/Write	Yes	
	0x02	X max	Integer 16		Read/Write	Yes	
	0x03	Y min	Integer 16		Read/Write	Yes	
	0x04	Y max	Integer 16		Read/Write	Yes	
	0x05	Z min	Integer 16		Read/Write	Yes	
	0x06	Z max	Integer 16		Read/Write	Yes	
	0x07	Enable Limit XY	Unsigned 8		Read/Write	Yes	
	0x08	Enable Limit Z	Unsigned 8		Read/Write	Yes	
	0x09	Enable Emergency XY	Unsigned 8		Read/Write	Yes	
0x10	Enable Emergency Z	Unsigned 8		Read/Write	Yes		

TPDO1 Settings

Index	Sub Index	Name	Type	Value	Access	Save	Comment
0x4510	0x00	Number of Entries	Unsigned 8	4	Read Only	No	If Enable 1 is set, TPDO is sent when the slope value changes by the value entered in the delta sub indexes.
	0x01	Enable	Unsigned 8	0	Read/Write	Yes	
	0x02	Delta Slope Long	Integer 16	0	Read/Write	Yes	
	0x03	Delta Slope Lateral	Integer 16	0	Read/Write	Yes	
	0x04	Delta Slope Angle 360	Integer 16	0	Read/Write	Yes	

Internal Time Value

Index	Sub Index	Name	Type	Value	Access	Save	Comment
0x05000	0x00	Internal Time Value	Unsigned 32		Read Only	No	time value that is increasing per 1 ms

Angle 360

Index	Sub Index	Name	Type	Value	Access	Save	Comment
0x05010	0x00	Angle 360	Integer 16 ($\pm 180^\circ$ ise) Unsigned 16 (0-360° ise)		Read Only	No	Angle value

Angle 360 Operating Parameter

Index	Sub Index	Name	Type	Value	Access	Save	Comment
0x05011	0x00	Angle 360 Operating Parameter	Unsigned 8	0	Read/Write	Yes	See CiA 410 0x6011

Angle 360 Preset Value

Index	Sub Index	Name	Type	Value	Access	Save	Comment
0x05012	0x00	Angle360 Preset Value	Integer 16	0	Read/Write	Yes	See CiA 410 0x6012

Angle 360 Offset

Index	Sub Index	Name	Type	Value	Access	Save	Comment
0x05013	0x00	Angle 360 Offset	Integer 16	0	Read/Write	Yes	See CiA 410 0x6013

Differential Angle 360 Offset

Index	Sub Index	Name	Type	Value	Access	Save	Comment
0x05014	0x00	Differential Angle 360 Offset	Integer 16		Read/Write	Yes	See CiA 410 0x6014

Angle 360 Format

Index	Sub Index	Name	Type	Value	Access	Save	Comment
0x05015	0x00	Angle 360 Format	Unsigned 8		Read/Write	Yes	Angle(0x5010) is shown as $\pm 180^\circ$ if value is 0, shown as 0-360° if value is 1.

4.2 Standardized Device Profile

Resolution

Index	Sub Index	Name	Type	Value	Access	Save	Comment
0x6000	0x00	Resolution	Unsigned 16	0x0064	Read Only	No	0,1°

Slope Long 16

Index	Sub Index	Name	Type	Value	Access	Save	Comment
0x6010	0x00	Slope Long 16	Integer 16		Read Only	No	X axis tilt information

Slope Long 16 Operating Parameter

Index	Sub Index	Name	Type	Value	Access	Save	Comment
0x6011	0x00	Slope Long 16 Operating Parameter	Unsigned 8		Read/Write	Yes	See CiA 410

Slope Long 16 Preset Value

Index	Sub Index	Name	Type	Value	Access	Save	Comment
0x6012	0x00	Slope Long 16 Preset Value	Integer 16		Read/Write	Yes	See CiA 410

Slope Long 16 Offset

Index	Sub Index	Name	Type	Value	Access	Save	Comment
0x6013	0x00	Slope Long 16 Offset	Integer 16		Read/Write	Yes	See CiA 410

Differential Slope Long 16 Offset

Index	Sub Index	Name	Type	Value	Access	Save	Comment
0x6014	0x00	Differential Slope Long 16 Offset	Integer 16		Read/Write	Yes	See CiA 410

Slope Lateral 16

Index	Sub Index	Name	Type	Value	Access	Save	Comment
0x6020	0x00	Slope Lateral 16	Integer 16		Read Only	No	Y axis tilt information

Slope Lateral 16 Operating Parameter

Index	Sub Index	Name	Type	Value	Access	Save	Comment
0x6021	0x00	Slope Lateral 16 Operating Parameter	Unsigned 8		Read/Write	Yes	See CiA 410

Slope Lateral 16 Preset Value

Index	Sub Index	Name	Type	Value	Access	Save	Comment
0x6022	0x00	Slope Lateral 16 Preset Value	Integer 16		Read/Write	Yes	See CiA 410

Slope Lateral 16 Offset

Index	Sub Index	Name	Type	Value	Access	Save	Comment
0x6023	0x00	Slope Lateral 16 Offset	Integer 16		Read/Write	Yes	See CiA 410

Differential Slope Lateral 16 Offset

Index	Sub Index	Name	Type	Value	Access	Save	Comment
0x6024	0x00	Differential Slope Lateral 16 Offset	Integer 16		Read/Write	Yes	See CiA 410

4.3 Communication Profile Area

Device Type

Index	Sub Index	Name	Type	Value	Access	Save	Comment
0x1000	0x00	Device Type	Unsigned 32	0x0002019A	Read Only	No	

Error Register

Index	Sub Index	Name	Type	Value	Access	Save	Comment
0x1001	0x00	Error Register	Unsigned 8		Read Only	No	

Pre-Defined Error Field

Index	Sub Index	Name	Type	Value	Access	Save	Comment
0x1003	0x00	Number of Errors	Unsigned 8	Up to 8	Read/Write	No	
	0x01..0x08	History Errors	Unsigned 32	0	Read Only	No	Emergency error history.

SYNC COB-ID

Index	Sub Index	Name	Type	Value	Access	Save	Comment
0x1005	0x00	SYNC COB-ID	Unsigned 32		Read/Write	Yes	

Manufacturer Device Name

Index	Sub Index	Name	Type	Value	Access	Save	Comment
0x1008	0x00	Manufacturer Device Name	String	Inclinometer	Read Only	No	

Manufacturer Hardware Version

Index	Sub Index	Name	Type	Value	Access	Save	Comment
0x1009	0x00	Manufacturer Hardware Version	String	V1.0	Read Only	No	

Manufacturer Software Name

Index	Sub Index	Name	Type	Value	Access	Save	Comment
0x100A	0x00	Manufacturer Software Version	String	V1.0	Read Only	No	

Store Parameters

Index	Sub Index	Name	Type	Value	Access	Save	Comment
0x1010	0x00	Number of Entries	Unsigned 8	1	Read Only	No	
	0x01	Save all parameters	Unsigned 32	0x02	Read/Write	No	The modified parameter is saved automatically.

Restore Parameters

Index	Sub Index	Name	Type	Value	Access	Save	Comment
0x1011	0x00	Number of Entries	Unsigned 8	1	Read Only	No	
	0x01	Restore all parameters	Unsigned 32	1	Read/Write	No	When the value 0x64616F6C is typed, the default parameters are loaded.

Emergency COB-ID

Index	Sub Index	Name	Type	Value	Access	Save	Comment
0x1014	0x00	Emergency COB-ID	Unsigned 32	Node ID+0x80	Read/Write	Yes	

Inhibit Time Emergency

Index	Sub Index	Name	Type	Value	Access	Save	Comment
0x1015	0x00	Inhibit Time Emergency	Unsigned 16	0	Read/Write	Yes	

Producer Heartbeat Time

Index	Sub Index	Name	Type	Value	Access	Save	Comment
0x1017	0x00	Producer Heartbeat Time	Unsigned 16	0	Read/Write	Yes	

Identity

Index	Sub Index	Name	Type	Value	Access	Save	Comment
0x1018	0x00	Number of Entries	Unsigned 8	4	Read Only	No	
	0x01	Vendor ID	Unsigned 32	0	Read Only	No	
	0x02	Product Code	Unsigned 32	0	Read Only	No	
	0x03	Revision Number	Unsigned 32	0	Read Only	No	
	0x04	Serial Number	Unsigned 32	0	Read Only	No	

Server SDO Parameter

Index	Sub Index	Name	Type	Value	Access	Save	Comment
0x1200	0x00	Number of Entries	Unsigned 8	2	Read Only	No	
	0x01	COB-ID Client to Server	Unsigned 32	NODE ID +0x600	Read Only	No	
	0x02	COB-ID Server to Client	Unsigned 32	NODE ID +0x580	Read Only	No	

Transmit PDO 1 Parameters

Index	Sub Index	Name	Type	Value	Access	Save	Comment
0x1800	0x00	Number of Entries	Unsigned 8	6	Read Only	No	
	0x01	COB-ID	Unsigned 32	NODE ID +0x180	Read/Write	Yes	When the Node ID (0x3001) is set, it is set automatically.
	0x02	Transmission Type	Unsigned 8	0xFE	Read/Write	Yes	
	0x03	Inhibit Time	Unsigned 16	0	Read/Write	Yes	
	0x04	Compatibility Entry	Unsigned 8	0	Read/Write	Yes	
	0x05	Event Timer	Unsigned 16	0X0064	Read/Write	Yes	100 ms
	0x06	SYNC Start Value	Unsigned 8	0	Read/Write	Yes	

Transmit PDO 1 Mapping

Index	Sub Index	Name	Type	Value	Access	Save	Comment
0x1A00	0x00	Number of Entries	Unsigned 8	4	Read/Write	Yes	
	0x01	PDO 1 Mapping for a process data variable 1	Unsigned 32	0x60100010	Read/Write	Yes	Slop Long (0x6010)
	0x02	PDO 1 Mapping for a process data variable 2	Unsigned 32	0x60200010	Read/Write	Yes	Slop Lateral (0x6020)
	0x03	PDO 1 Mapping for a process data variable 3	Unsigned 32	0x50100010	Read/Write	Yes	Angle 360 (0x5010)
	0x04	PDO 1 Mapping for a process data variable 4	Unsigned 32	0x27000008	Read/Write	Yes	Internal Temperature (0x2700)

4.4 Manufacturer Specific Emergency Objects

Message	Node	COB-ID	Data (Hex)	Comment
Emergency	0x01	0x081 (0x080 + Node Id)	00 42 09 00 00 00 00 00	Appears when the values specified in Index 0x2701 are exceeded.
Emergency	0x01	0x081 (0x080 + Node Id)	10 50 29 00 00 00 00 00	Appears when the X-axis values entered in Index 0x4500 are exceeded.
Emergency	0x01	0x081 (0x080 + Node Id)	20 50 29 00 00 00 00 00	Appears when the Y axis values entered in Index 0x4500 are exceeded.
Emergency	0x01	0x081 (0x080 + Node Id)	30 50 20 00 00 00 00 00	Appears when the Z-axis values entered in Index 0x4500 are exceeded.

ATEK ELEKTRONİK SENSÖR TEKNOLOJİLERİ SANAYİ VE TİCARET A.Ş.

 Gebze OSB, 800. Sokak, No:814 Gebze/KOCAELİ/TÜRKİYE

 Tel : +90 (262) 673 76 00

 Fax : +90 (262) 673 76 08

 Web : www.ateksensor.com

 E-mail : info@ateksensor.com