

AWE 404

“High strength stainless steel wire”

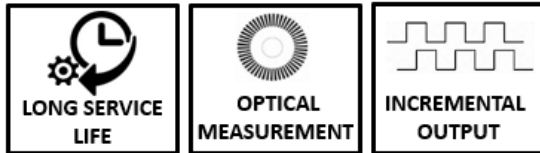

- Different stroke (measuring) lengths between 0...1000 mm and 0...4000 mm
- Incremental output
- Stainless steel measuring wire
- IP54 protection class (Optional IP67)
- Compact design
- Easy installation
- 2 m/s maximum speed
- Shock/Vibration resistant
- Aluminum body

AWE 404 series wire encoders convert linear motion into incremental digital pulses. They have different stroke lengths up to 4000 mm. Optionally other resolutions, cable lengths and socket connectors can be requested.

They make measurement by pulling and rewinding stainless steel wire. Usage is practical and usage area is quite wide. By connecting to a counter or position controller, they become a perfect system in high resolutions for position control in wood processing, marble machines, glass processing machines and other machines.

MECHANICAL DATA

Mechanical and Environmental Data

Stroke Length	Different measuring lengths between 0...1000 mm and 0...4000 mm	
Linearity	±0.03% FS	
Maximum Speed	2 m/s	
Required force	5 N	
Protection Class	IP54 (Optional IP67)	
Operating Temperature	-25°C ... +85°C	
Relative Humidity	%95	
Material	Body	Aluminum/steel /plastic
	Measuring wire	Stainless steel

MECHANICAL DIMENSIONS (mm)

M12 Connector Output From Backside

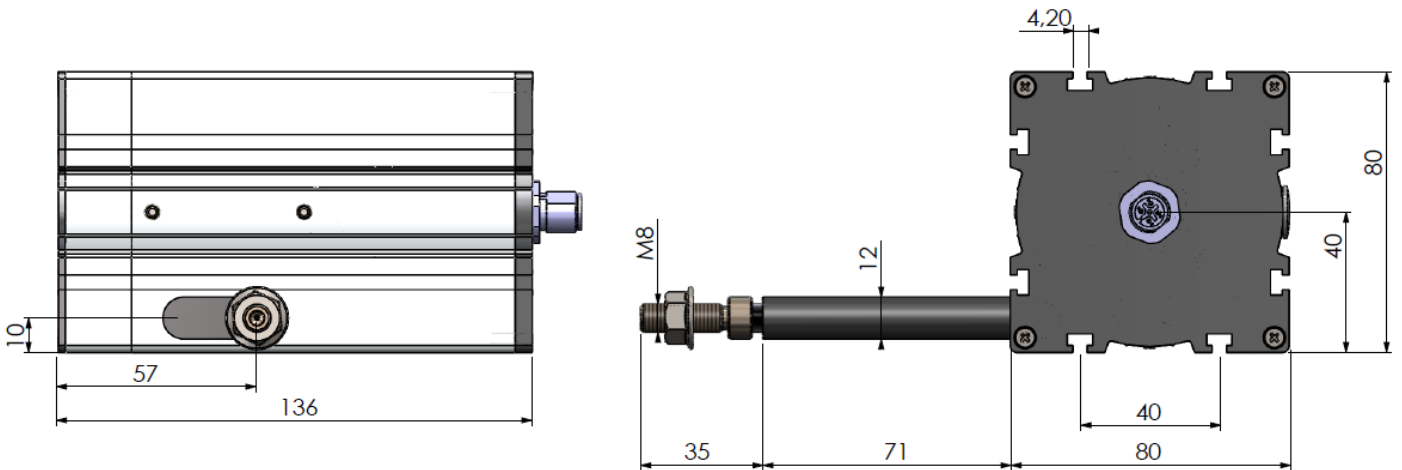

M12 Connector Output From Side

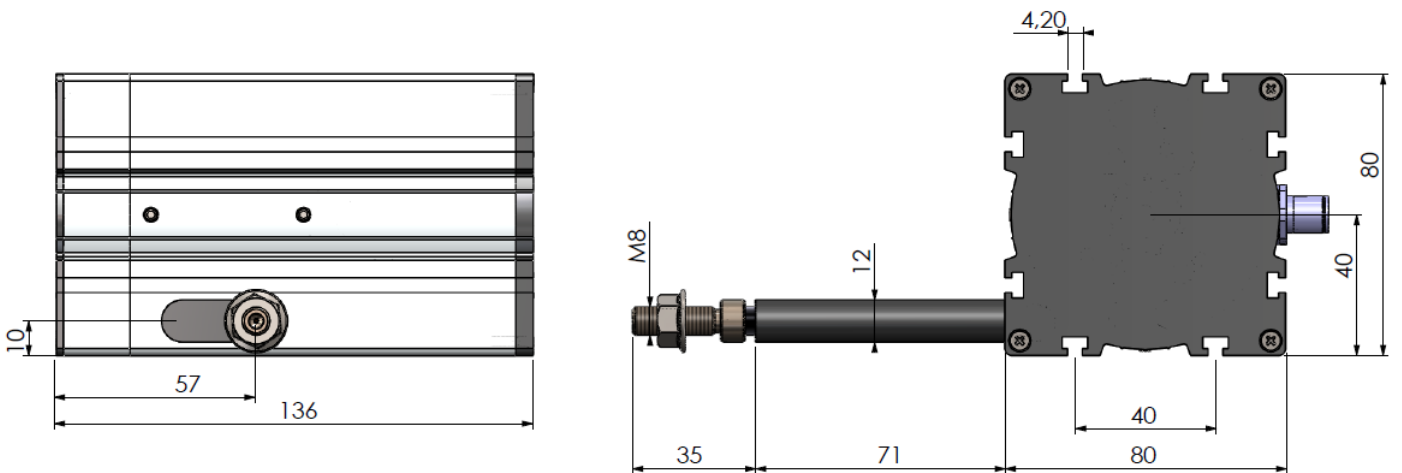

Cable Output From Backside

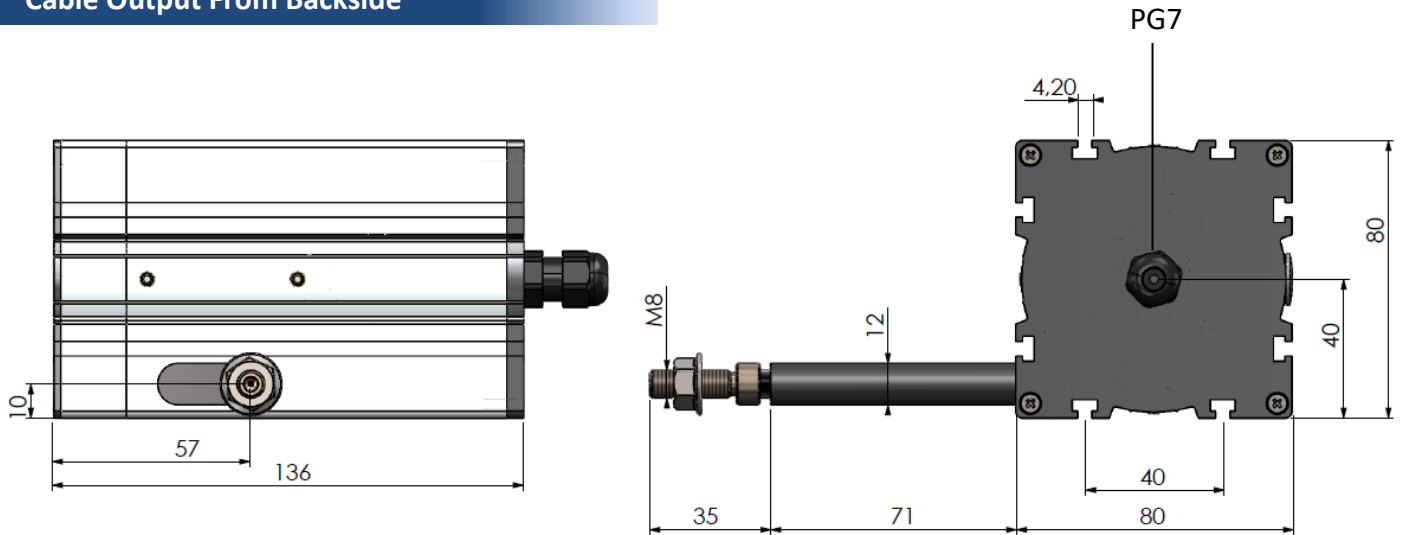

Cable Output From Side

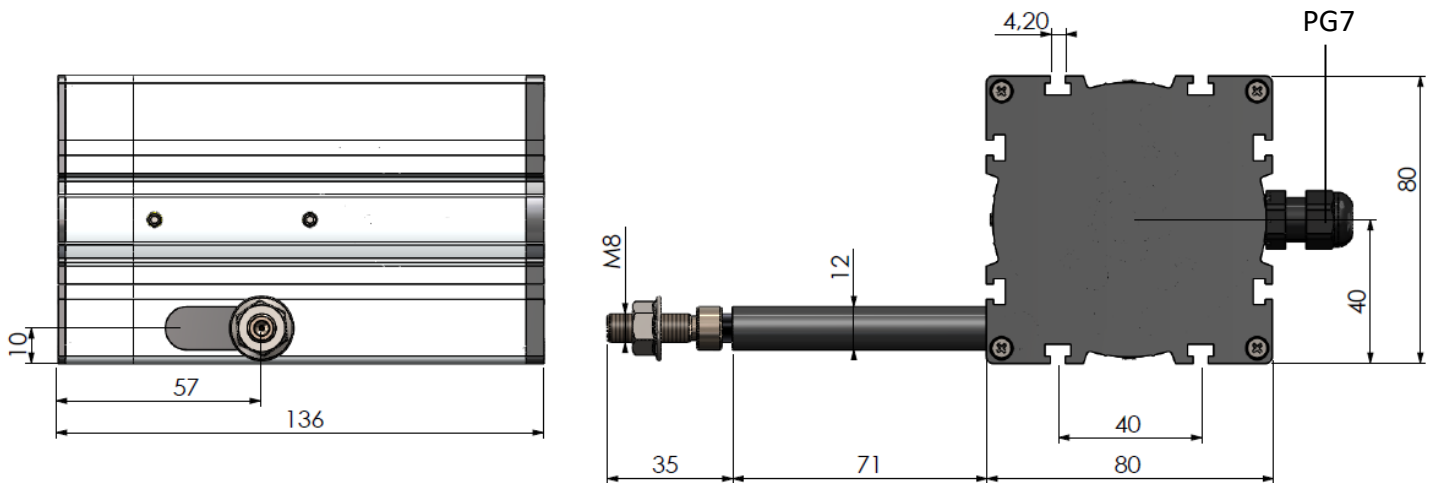

ELECTRICAL DATA

Measuring Type	Optical		
*Resolution	pulse/mm	mm/edge	
	5 pulses/mm	0.05 mm	
	10 pulses/mm (std)	0.025 mm (std)	
	20 pulse/mm	0.0125 mm	
*Electrical Interface	Supply	Output	
	PP	10...30 VDC	10...30 VDC Push-Pull
	TTL	5 VDC	5VDC TTL RS422 Line Driver
	HTL	10...30 VDC	5VDC TTL RS422 Line Driver
	HPL	5...30 VDC	5...30 VDC Push-Pull
*Output Signals	A,B,Z (standard) A,B A,/A,B,/B A,/A,B,/B,Z,/Z		
Max Output Current	60 mA (per channel)		
*Electrical Connection	5 or 8x0,14 mm ² shielded cable M12 / 8 pin male connector		

ELECTRICAL CONNECTIONS

SIGNAL	CABLE COLOR	M12 8 PIN MALE CONN. PIN NO
A	Yellow	1
B	Green	2
+V	Red	3
0V	Black	4
Z	Pink	5
/A	Blue	6
/B	White	7
/Z	Grey	8
EARTH	Silver	-

In the right table the cable colors of sensors output signals are given. If the control circuit is suitable in the Line Driver sensors of the not output signals (/A, /B, /Z) have to be added to the system. If it is not suitable /A, /B, /Z signal cables must be fixed as insulated separately. Don't forget that these edges have electricity too.

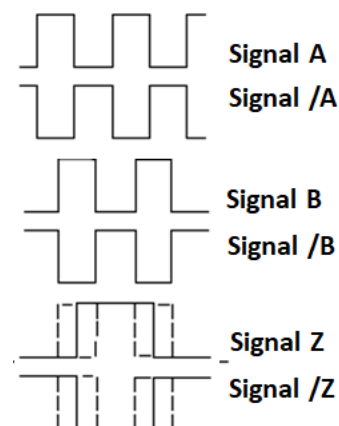

SAMPLE APPLICATION FIELDS

- Elevators
- Press machines
- Crane systems
- Wood processing machines
- Marble processing machines
- Storage positioning
- Dam protections
- Sluice gate control
- Air compressors
- Glass processing machines
- Lifting platforms
- Applications in medical technologies (operating table etc.)
- Forklifts
- Screw machines
- Paper machines
- Sewing machines
- Hydraulic machines
- Sheet metal machines
- Printing machines
- Horizontal control equipments
- Construction machines
- Industrial robots
- Injection machines
- X-Y axis displacement
- Liquid level measurements and position control

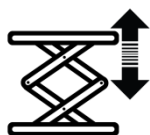

ORDER CODE

Model	Stroke Length			Output Signals			Cable or Socket Direction							
	XX	XXXX	XXX	X	XX	X	XXXX							
	Different measuring lengths between 0...1000 mm and 0...4000 mm			2 (A,B) 3 (A,B,Z) (standard) 4 (A,/A,B,/B) 6 (A,/A,B,/B,Z,/Z)			B : From backside S : From side							
AWE 404	-	XX	-	XXXX	-	XXX	-	X	-	XX	-	X	-	XXXX
	Resolution			Supply and Output			Electrical Connection			Protection Class				
	05 : 0.05 mm/pulse 01 : 0.1 mm/pulse (standard) 02 : 0.2 mm/pulse			PP : 10...30 VDC Supply : 10...30VDC Push-Pull Output TTL : 5 VDC Supply : 5 VDC TTL RS422 Line Driver Output HTL : 10...30 VDC Supply : 5 VDC TTL RS422 Line Driver Output HPL : 5...30 VDC Supply (standard) : 5...30 VDC Push-Pull Output			3M : 3m (standard) 5M : 5m 10M : 10m S14M : M12 / 8 Pin Male Conn.			No code : IP54 (std) E067 : IP67				

MOUNTING AND WARNINGS

1. Never release the wire after pulling. Otherwise, the coil spring will be damaged.

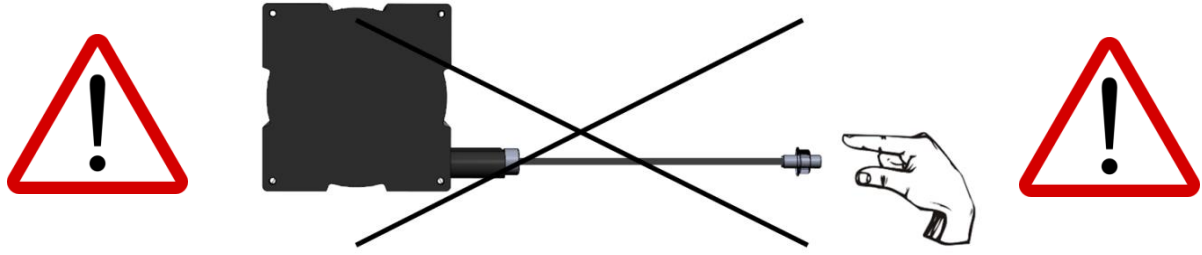

2. Mount the sensor according to the mounting directions shown below.

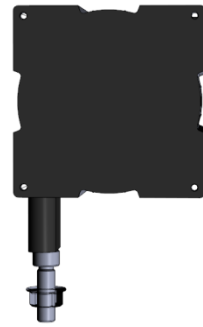
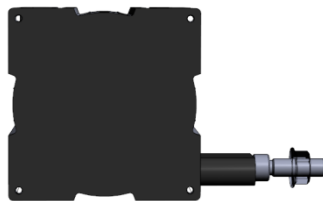
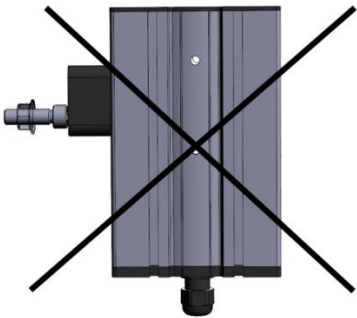

3. If there is a trickle of water (like a rain), the wire outlet must not be a drip of water upstream. If needed please use guide rollers.

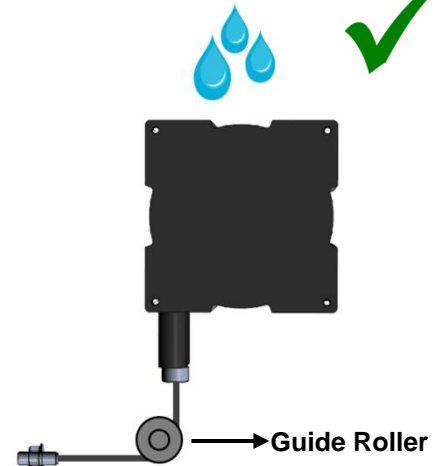
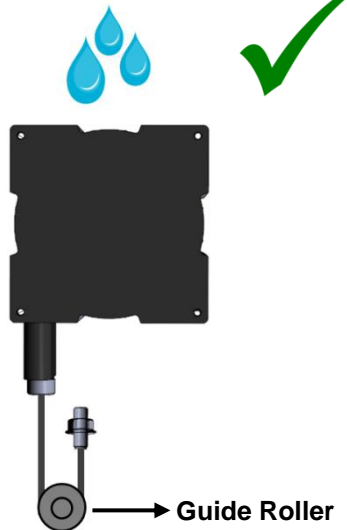

4. The wire should not be pulled in angular. If needed, please use guide rollers.

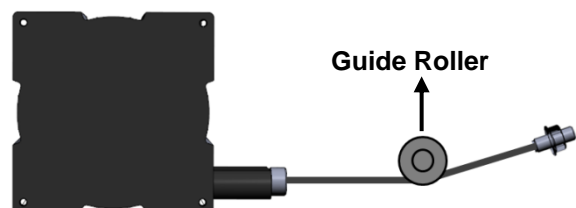
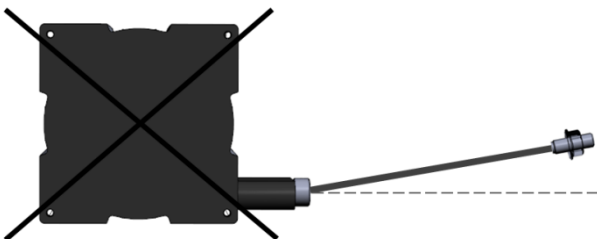

Important Note(!): Failure to comply with these recommendations, the malfunctions that may occur will not be under the warranty.