

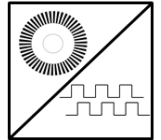

GENERAL FEATURES

- Measuring length up to 22000 mm
- Incremental output
- Stainless steel measuring wire
- Standard IP53, optional IP67 protection class
- Compact design
- Easy installation
- 2 m/s maximum speed
- Shock/Vibration resistant
- Aluminum body



AWE 722 series wire encoders convert linear motion into incremental digital pulses. They have a measuring length up to 22000 mm. Optionally other resolutions, cable lengths and socket connectors can be requested.

They make measurement by pulling and rewinding stainless steel wire. Usage is practical and usage area is quite wide. By connecting to a counter or position controller, they become a perfect system in high resolutions for position control in wood processing, marble machines, glass processing machines and other machines.

TECHNICAL SPECIFICATIONS

Stroke Length	Up to 22000 mm		Accuracy	±%0.03 FS	
*Resolution	pulse/mm	mm/edge	Maximum Speed	2 m/s	
	3 pulse/mm	0.075 mm	Required force	12 N	
*Electrical Interface	Power Supply	Output	Max Output Current	60 mA (per channel)	
	PP	10...30 VDC	10...30 VDC Push-Pull	Measuring Type	Optical
	TTL	5 VDC	5VDC TTL RS422 Line Driver	*Electrical Connection	5 or 8x0,14 mm ² shielded cable M12 / 8 pin socket
	HTL	10...30 VDC	5VDC TTL RS422 Line Driver	Materials	Housing: Aluminum
HPL	5...30 VDC	5...30 VDC Push-Pull	Measuring Wire: Stainless steel		
*Output Signals	A,B,Z (standard)		IP Protection Class	IP53 (optional IP67)	
	A,B		Operating Temperature	-25°C ... +85°C	
	A,/A,B,/B		Relative Humidity	%95	
	A,/A,B,/B,Z,/Z		Weight	≈13 kg	

Note: The technical specifications indicated by (*) vary according to the selected model. The detailed code table is shown on page 4.

ELECTRICAL CONNECTION

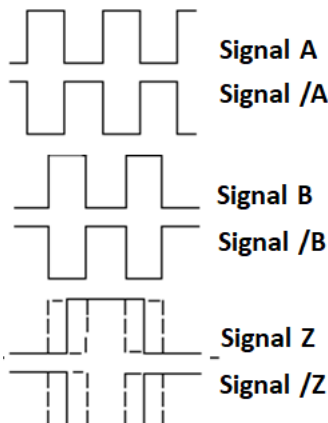

In the right table the cable colors of sensors output signals are given. If the control circuit is suitable in the Line Driver sensors of the not output signals (/A, /B, /Z) have to be added to the system. If it is not suitable /A, /B, /Z signal cables must be fixed as insulated separately. Don't forget that these edges have electricity too.

SIGNAL	CABLE COLOR	M12 SOCKET PIN NO
A	Yellow	1
B	Green	2
+V	Red	3
0V	Black	4
Z	Pink	5
/A	Blue	6
/B	White	7
/Z	Grey	8
EARTH	Silver	-

MECHANICAL DIMENSIONS (mm)

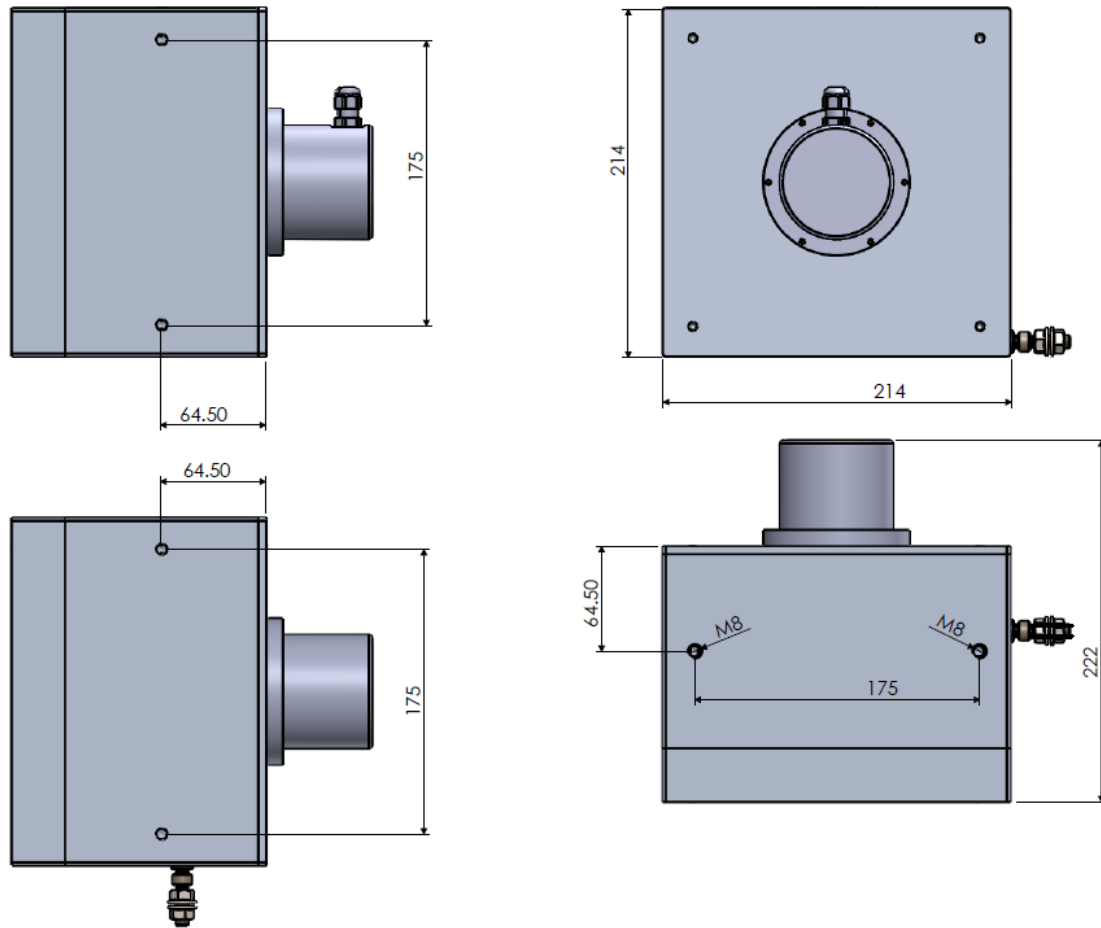

SAMPLE APPLICATION FIELDS

- Elevators
- Press machines
- Crane systems
- Wood processing machines
- Marble processing machines
- Storage positioning
- Dam protections
- Sluice gate control
- Air compressors
- Glass processing machines
- Lifting platforms
- Applications in medical technologies (operating table etc.)
- Forklifts
- Screw machines
- Paper machines
- Sewing machines
- Hydraulic machines
- Sheet metal machines
- Printing machines
- Horizontal control equipments
- Construction machines
- Industrial robots
- Injection machines
- X-Y axis displacement
- Liquid level measurements and position control

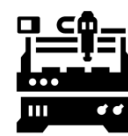
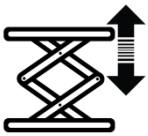

MOUNTING AND WARNINGS

1. Never release the wire after pulling. Otherwise, the coil spring will be damaged.

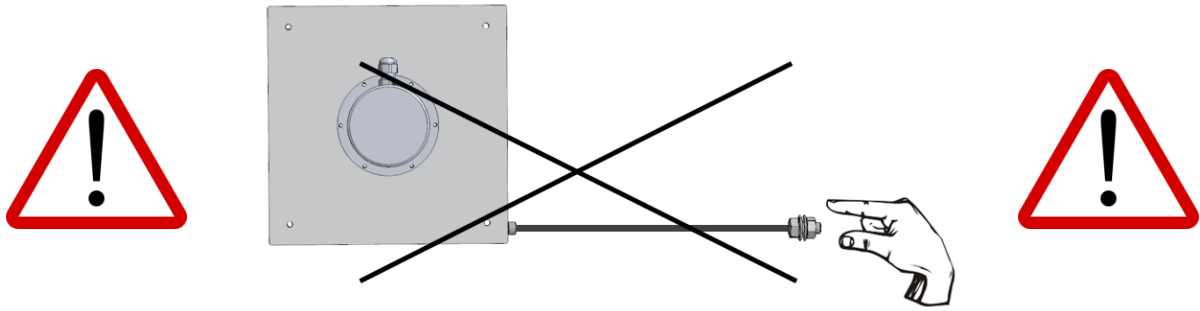

2. Mount the sensor according to the mounting directions shown below.

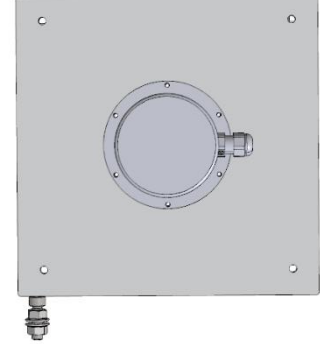
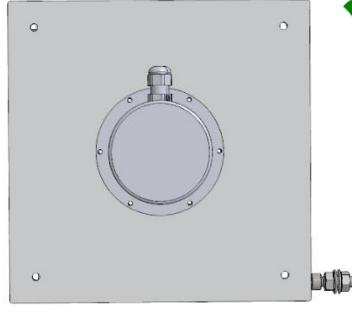
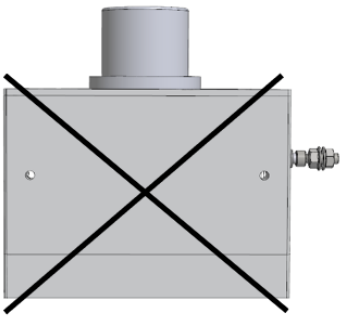

3. If there is a trickle of water (like a rain), the wire outlet must not be a drip of water upstream. If needed please use guide rollers.

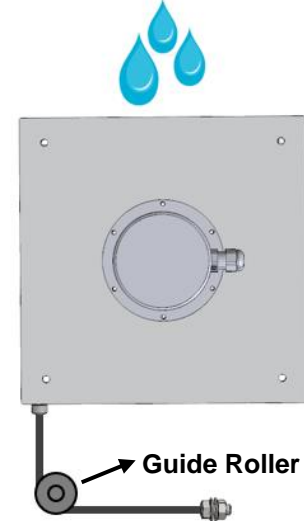
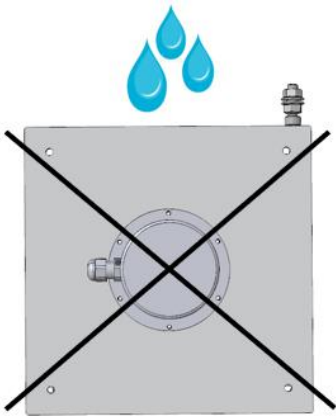

4. The wire should not be pulled in angular. If needed, please use guide rollers.

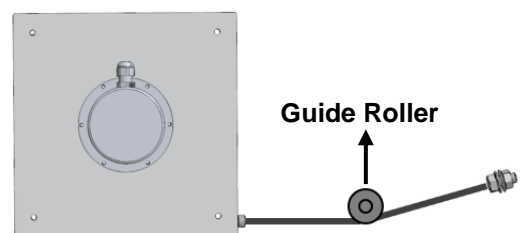
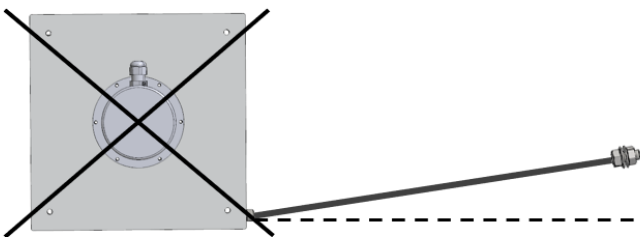

Important Note(!): Failure to comply with these recommendations, the malfunctions that may occur will not be under the warranty.

PRODUCT CODE

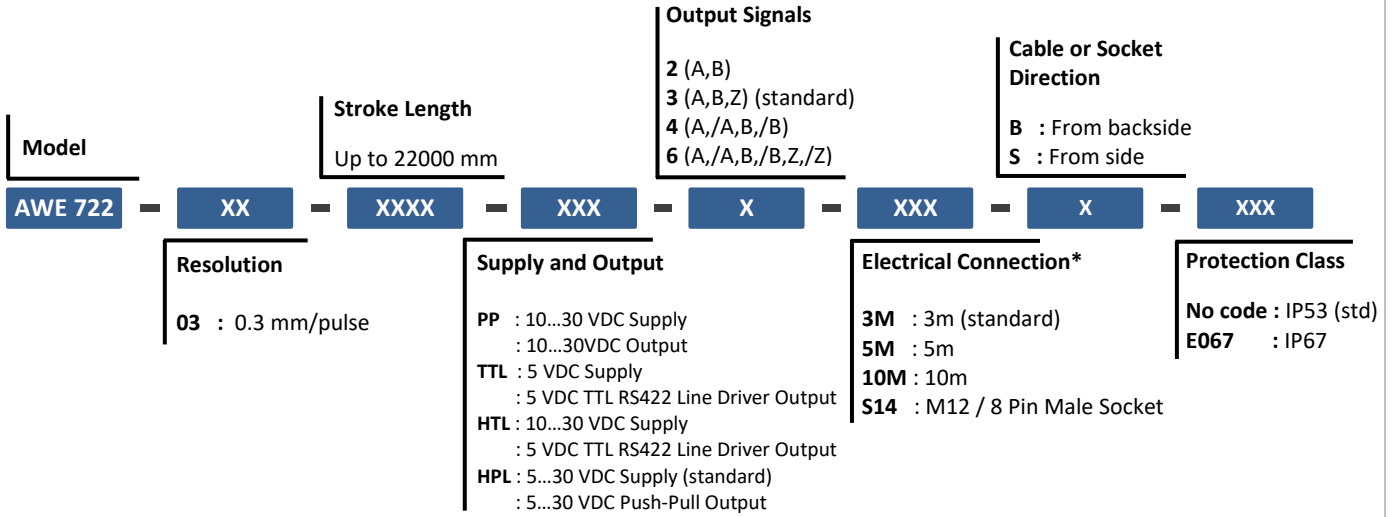

(*) Please contact for other (customized) options.

Atek Elektronik Sensör Teknolojileri Sanayi ve Ticaret A.Ş.

 Gebze OSB, 800. Sokak, No:814 Gebze/KOCAELİ/TURKEY
 Tel: +90 262 673 76 00  Fax: +90 262 673 76 08
 www.ateksensor.com  info@ateksensor.com