

**CLS 410**

## CAPACITIVE LEVEL SENSOR



- Capacitive measurement principle
- Output options: 4–20 mA (3-wire), 0–10 V, 0.5–4.5 V, 0–5 V, RS-485, CANopen, switch output (NO/NC)
- Mechanical connection options: M16, G1/2", G1", and G1-1/2"
- High accuracy and stability
- IP67 protection class

The measurement system is based on the capacitive measurement principle. A capacitor structure is formed between the measurement probe and the tank wall or the reference electrode, and the product inside the tank acts as the dielectric medium. As the product level inside the tank changes, the capacitance value between the probe and the tank also changes.

The resulting capacitance change is detected by the electronic evaluation unit and is continuously analyzed. The processed measurement data is calculated to correspond to the product level and is transmitted as percentage (%) level information or as an electrical output signal for use in process control and automation systems.

**APPLICATIONS**

- Liquid tanks
- Glycol tanks
- Food machinery
- Coolant tanks
- Clean water tanks
- Oil tanks
- High-temperature tanks
- Low-conductivity liquids
- Grain silos
- Cement silos
- Sand
- Hot adhesive and high-viscosity acids and chemical liquids

## MECHANICAL DIMENSIONS (mm)

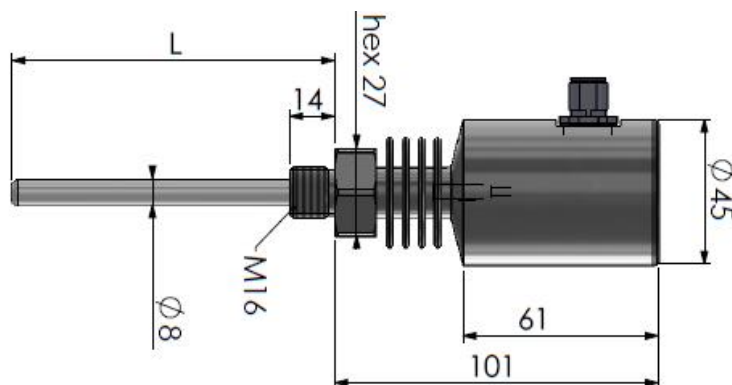

### L = Immersion Length (including thread)

0100: 100mm	0350: 350mm	0600: 600mm	0850: 850mm	1100: 1100mm	1350: 1350mm
0150: 150mm	0400: 400mm	0650: 650mm	0900: 900mm	1150: 1150mm	1400: 1400mm
0200: 200mm	0450: 450mm	0700: 700mm	0950: 950mm	1200: 1200mm	
0250: 250mm	0500: 500mm	0750: 750mm	1000: 1000mm	1250: 1250mm	
0300: 300mm	0550: 550mm	0800: 800mm	1050: 1050mm	1300: 1300mm	

\*Please ask for other options.

## TECHNICAL SPECIFICATIONS

ELECTRICAL DATA	
<b>Detectable Liquids</b>	Water - Oil
<b>Supply Voltage</b>	4-20mA (3 wire), 0.5-4.5VDC, 0-5VDC, RS485, CANopen
	12...24VDC
<b>Max. Load Current</b>	0-10VDC
<b>Output Signal</b>	1A (sink), 100mA (source)
<b>Output Type</b>	4-20mA (3 Telli), 0-10VDC, 0.5-4.5VDC, 0-5VDC, RS485, CANopen
<b>Measurement Principle</b>	SINK (NPN), SOURCE (PNP)
<b>Measurement Error</b>	Capacitive
<b>Measurement Range</b>	%±0.5 @25°C
<b>Operating Frequency</b>	10-1000 Pf
<b>Response Time</b>	50-400 kHz
<b>Short-Circuit Protection</b>	1 sn
<b>Reverse Polarity Protection</b>	Yes
<b>Overload Protection</b>	Yes
MECHANICAL DATA	
<b>Housing</b>	AISI 316L
<b>Insulation Material</b>	FEP
<b>Mechanical Connection</b>	M16, G1/2", G1", G1-1/2"
ENVIRONMENTAL DATA	
<b>Protection Class</b>	IP67
<b>Temperature Range</b>	Liquid: -40°C ... +85°C
	Storage: -40°C ... +85°C

## WARNINGS

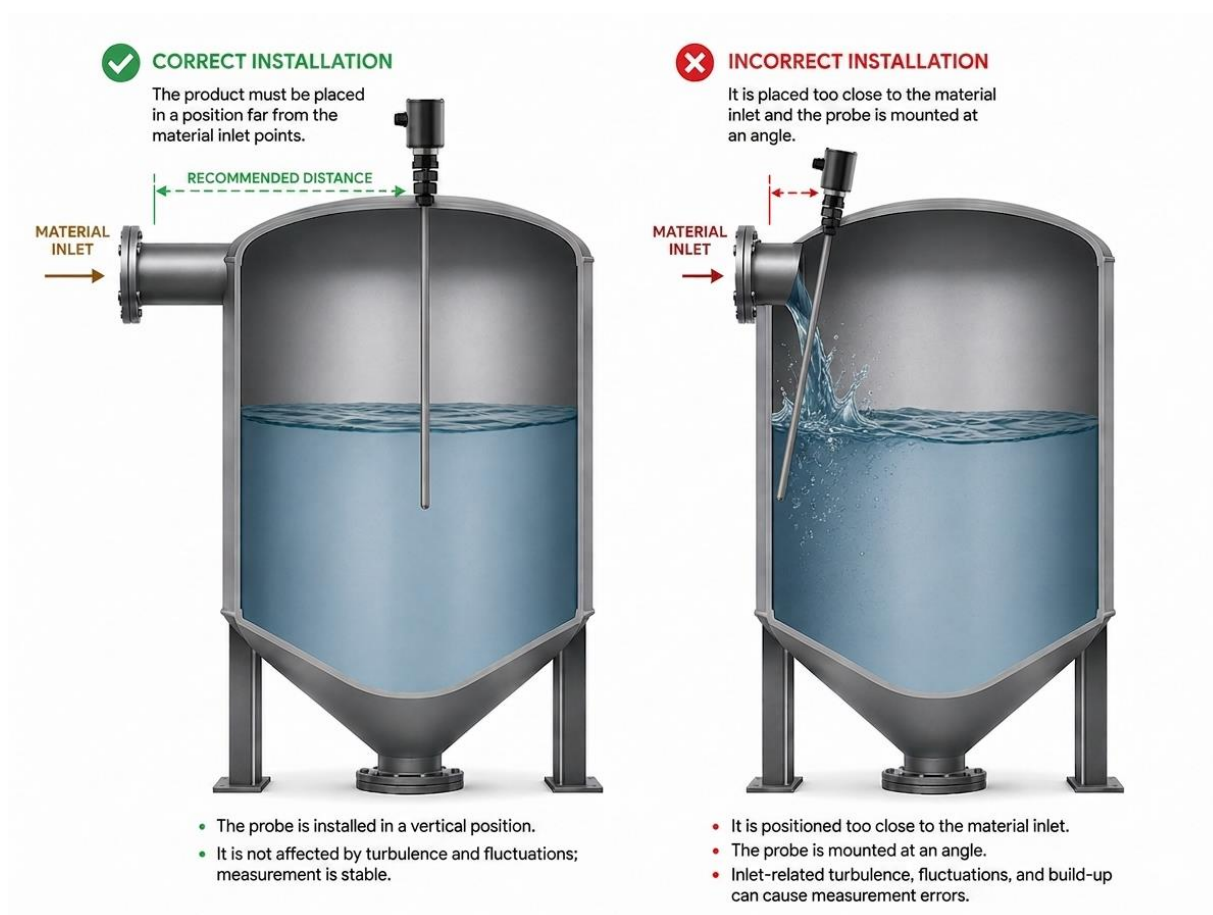

- Care must be taken to prevent damage to the measuring probe. If the measuring probe is damaged, accurate measurement cannot be performed.
- The connector/cable pins should be checked to ensure that they are clean and in proper condition.
- The connector/cable connection must be made as specified in the technical data.
- To prevent damage to the sensor, attention must be paid to the supply polarity and voltage specified in the technical data.
- The product should be installed at a location away from material inlet points.
- To prevent water from entering the device, the cable gland should be positioned facing downward during installation.
- If there are factors in the application area that may damage the product, it is recommended to install a protective shield at the measurement point.

## ORDER CODE

### 1- Model

**CLS 410**

### 2- L = Immersion Length (including thread)

<b>0100:</b> 100mm	<b>0350:</b> 350mm	<b>0600:</b> 600mm	<b>0850:</b> 850mm	<b>1100:</b> 1100mm	<b>1350:</b> 1350mm
<b>0150:</b> 150mm	<b>0400:</b> 400mm	<b>0650:</b> 650mm	<b>0900:</b> 900mm	<b>1150:</b> 1150mm	<b>1400:</b> 1400mm
<b>0200:</b> 200mm	<b>0450:</b> 450mm	<b>0700:</b> 700mm	<b>0950:</b> 950mm	<b>1200:</b> 1200mm	
<b>0250:</b> 250mm	<b>0500:</b> 500mm	<b>0750:</b> 750mm	<b>1000:</b> 1000mm	<b>1250:</b> 1250mm	
<b>0300:</b> 300mm	<b>0550:</b> 550mm	<b>0800:</b> 800mm	<b>1050:</b> 1050mm	<b>1300:</b> 1300mm	

**\* Thread Included**

**\* Please ask for other options**

### 3-Immersion Pipe Diameter (mm) ( $\varnothing$ D)

**08 :** 8 mm

**\* Please ask for other options**

### 4- Output Signal

**A7:** 4-20mA (3 wire)

**V1:** 0-5 VDC

**S2:** RS-485

**SNK:** Sink (NPN)

**V:** 0-10 VDC

**V3:** 0.5-4.5 VDC

**C:** CANopen

**SRC:** Source (PNP)

**\* Please ask for other options**

### 5- Mechanical Connection

**M16 :** M16

**G1/2 :** G1/2'

**G1 :** G1'

**G1-1/2 :** G1-1/2'

**\* Please ask for other options**

### 6- Electrical Connection

**M12:** M12/4pin

**\* Please ask for other options**

### 7- Material

**E316:** AISI 316 L

**\* Please ask for other options**

**SAMPLE ORDER CODE:** CLS 410 – 0100 – 08 – A7– G1/2 – M12 – E316