

### AST 50 Series

“-50 and +150 °C Measuring Range, 15-300 mm Immersion Length, PT100 or PT1000”



- Selectable measuring range from -50 to +150 °C (Optional others)
- Resistant up to 200Bar (for higher pressures please ask)
- Immersion length options ranging from 15 mm to 300 mm
- PT100 or PT1000 sensor
- G1/4, G1/2, NPT1/4, NPT1/2, M14x1, M20x1,5 etc. process connection options
- 304L stainless steel housing
- IP65 protection

## MECHANICAL DIMENSIONS (mm)

### DIN43650-A CONNECTOR

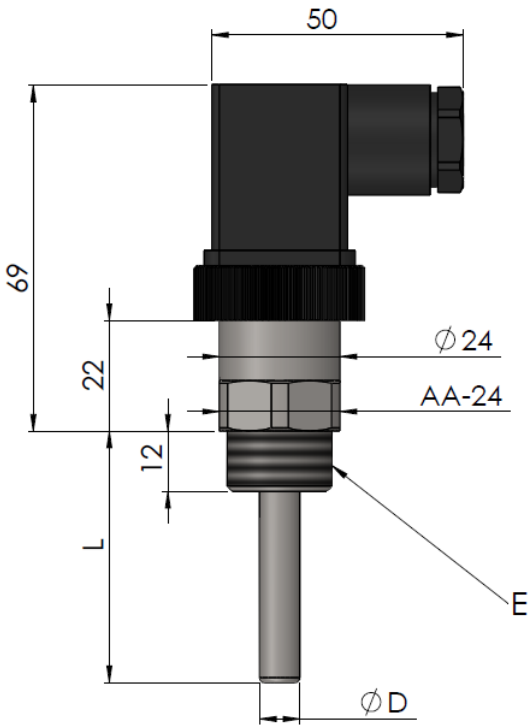

### DIN43650-C CONNECTOR

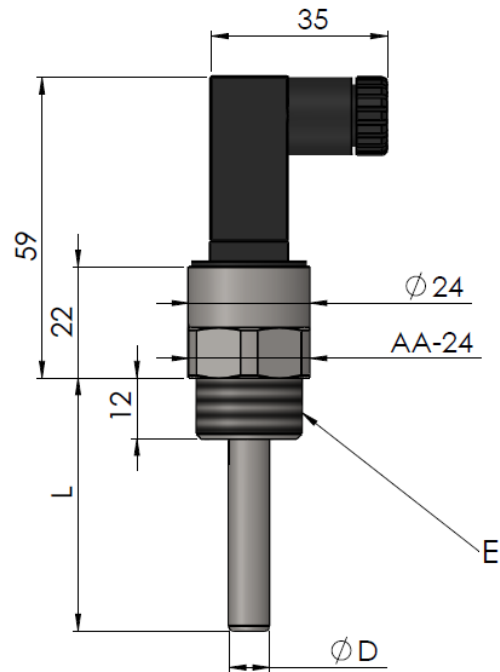

### M12 CONNECTOR

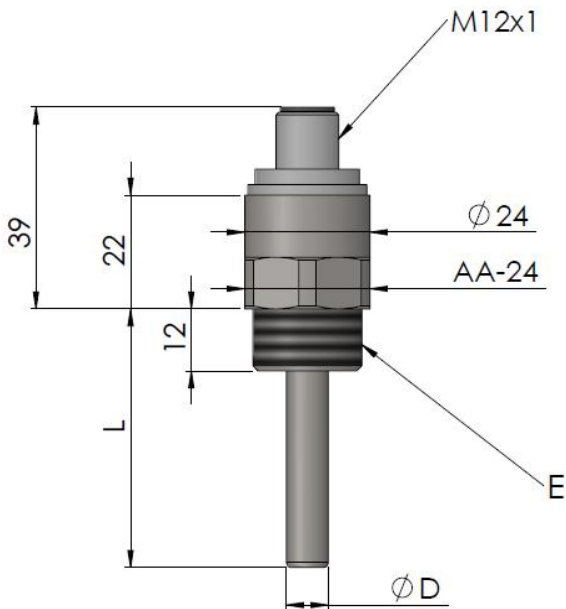

### CABLE OUTPUT

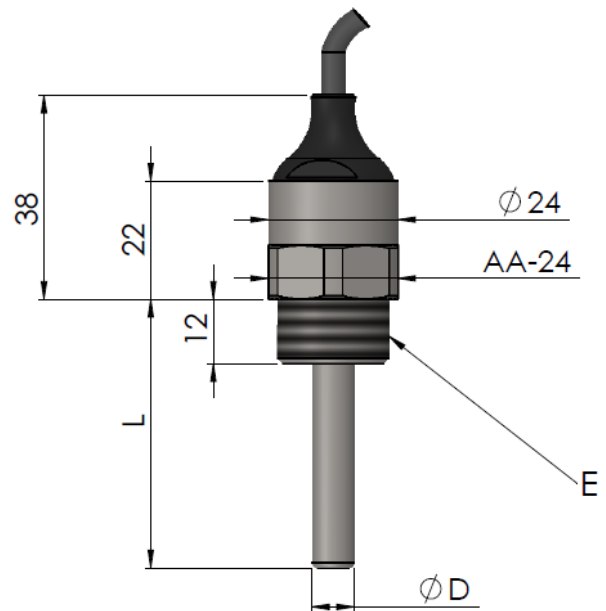

**E** : Process connection

**L** : Immersion length

**ØD** : Immersion diameter

\* For dimensions, see Technical Specifications

## TECHNICAL SPECIFICATIONS

<b>Measurement Sensor and Specifications</b>	PT100, PT1000 (Class B EN60751) Temperature Coefficient: 3850 TCR Self-heating: 0.2 K/mW at 0 °C Tolerance class: F 0.6 (2B)
<b>Measuring range</b>	-50 ... +150 °C (Optional others)
<b>Max. working pressure</b>	200 Bar (for higher pressures please ask)
<b>Output</b>	2 wire RTD, 3 wire RTD, 4 wire RTD
<b>Electrical connection</b>	DIN 43650-A, DIN 43650-C, M12 Connector, Cable
<b>Process Connection (E)</b>	G1/4, G1/2, NPT1/4, NPT1/2, M14x1, M20x1,5 (Optional others)
<b>Immersion length (L)</b>	Optional between 15 mm ... 300 mm
<b>Immersion Diameter (D)</b>	8mm 6mm (only for pressures up to 0...200 bar)
<b>Material</b>	AISI 304L
<b>Operating Temp. (head)</b>	-40°C ... +85°C
<b>Protection Class</b>	IP65

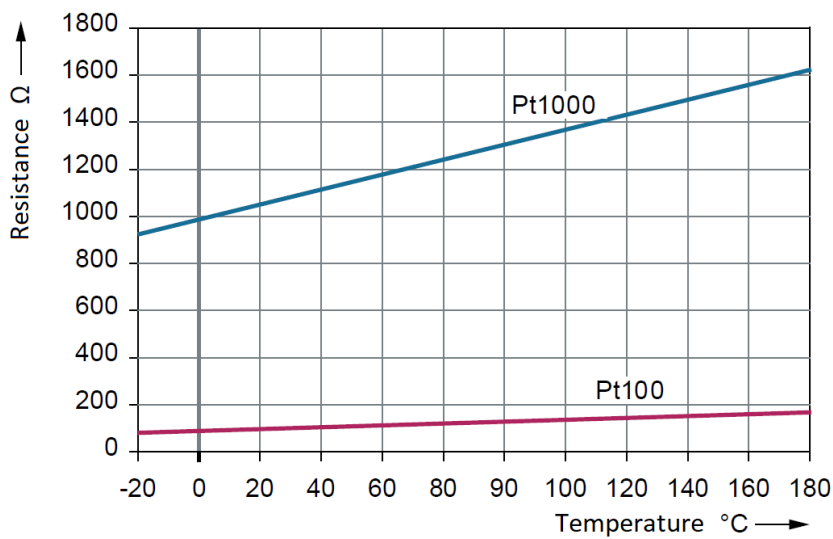

## ELECTRICAL CONNECTION

### RTD (1xPT100 or 1xPT1000) Connection

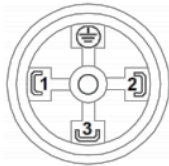
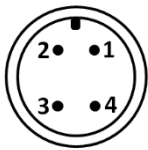
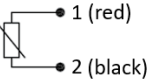
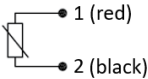
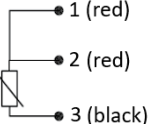
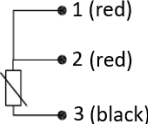
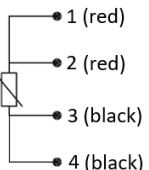
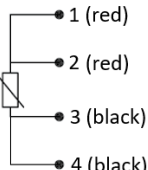
	 <b>DIN43650-A Connector</b>	 <b>M12 4 Pin Male Connector</b>
<b>2-Wire</b>		
<b>3-Wire</b>		
<b>4-Wire</b>		

## ORDER CODE

### 1-Model

AST50

### 2- Temperature Range

Selectable from -50 to +150 °C (Ask for others)

### 3- Immersion Length

015: 15mm	080: 80mm	250: 250mm
025: 25mm	100: 100mm	300: 300mm
050: 50mm	150: 150mm	
075: 75mm	200: 200mm	

**\*We do not recommend using small immersion lengths for air or gas temperature measurements, as the body absorbs heat due to the measurement probe being very close to the sensor body.**

### 4- Immersion Pipe Diameter

8: 8mm  
6: 6mm (only for pressures up to 0...200 bar)

### 5- Pressure Type

Y: High Pressure (For pressures higher than 200 bar)  
D: Low Pressure (For pressures up to 0...200 bar)

### 6- Sensor Type

PT100  
PT1000

### 7- Output Signal

RTD2 : 1xPT100 or 1xPT1000 (2-wire)  
RTD3 : 1xPT100 or 1xPT1000 (3-wire)  
RTD4 : 1xPT100 or 1xPT1000 (4-wire)

### 8- Process Connection

G1/4 : G1/4	NPT1/2 : NPT1/2
G1/2 : G1/2	M14 : M14x1
NPT1/4 : NPT1/4	M20 : M20X1,5

\* Optional others

### 9- Electrical Connection

S63 : DIN43650-A      S17 : M12 4 pin male connector      1M : 1 meters cable  
\* Optional others

### 10- Body Material

E304 : 304 Stainless Steel  
\* Optional others

**Sample Order Code:** AST50 -50...+150 015 8Y PT100 RTD2 G1/2 S63 E304