

AST 30 Series

“-195...+650°C Measuring Range, 25-500 mm Immersion Length, RTD Output”



- Selectable measuring range from -195 to +650 °C (Optional others)
- Resistant up to 200Bar (for higher pressures please ask)
- Immersion length options ranging from 25 mm to 500 mm
- RTD (PT100, PT1000) output
- G1/4, G1/2, NPT1/4, NPT1/2, M14x1, M20x1,5 etc. process connection options
- Aluminum alloy housing
- Easy installation and use

AST30 head type industrial high temperature sensor is designed for precise temperature measurement of liquid and gaseous media in the range of -195 to +650 °C.

The detection principle is based on the variation of the electrical resistance of the conductor with temperature. The resistance signal receiving from the RTD element is integrated into automation systems.

It has a wide range of user-selectable specifications such as measuring range, process connection type, immersion length, output signal, connector type etc.

APPLICATIONS

- Machines
- Tanks
- Boilers
- Gas and liquid fluids
- Surface temp. measurement
- Ambient temp. measurement

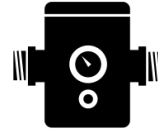

MECHANICAL DIMENSIONS (mm)

For Low Temperatures ($\leq +200^{\circ}\text{C}$)

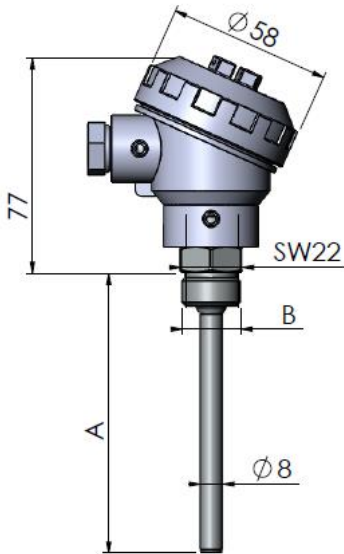

STROKE	A	B
025	25	G1/2 G1/4 NPT1/4 NPT1/2 M14x1 M20x1,5 *Optional others
050	50	
075	75	
100	100	
125	125	
150	150	
175	175	
200	200	
225	225	
250	250	
275	275	
300	300	
325	325	
350	350	
375	375	
400	400	
425	425	
450	450	
475	475	
500	500	

For High Temperatures ($> +200^{\circ}\text{C}$)

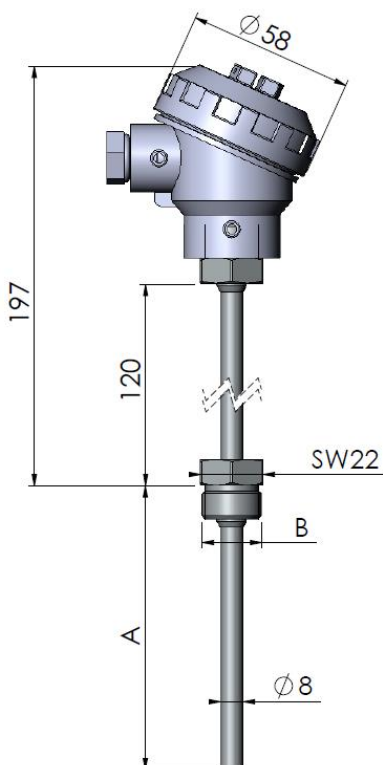



STROKE	A	B
025	25	G1/2 G1/4 NPT1/4 NPT1/2 M14x1 M20x1,5 *Optional others
050	50	
075	75	
100	100	
125	125	
150	150	
175	175	
200	200	
225	225	
250	250	
275	275	
300	300	
325	325	
350	350	
375	375	
400	400	
425	425	
450	450	
475	475	
500	500	

TECHNICAL SPECIFICATIONS

Measurement Sensor and Specifications	PT100, PT1000 (Class B EN60751) Temperature Coefficient: 3850 TCR Self-heating: 0.2 K/mW at 0 °C Tolerance class: F 0.6 (2B)
Measuring range	-195 ... +650 °C / -319 ... +1202 °F (Optional others)
Max. working pressure	200 Bar (for higher pressures please ask)
Output	2 wire RTD, 3 wire RTD, 4 wire RTD
Electrical connection	Terminal
Process Connection	G1/4, G1/2, NPT1/4, NPT1/2, M14x1, M20x1,5 (Optional others)
Immersion length	Optional between 25 mm ... 500 mm
Immersion Diameter	8mm 6mm (only for pressures up to 0...200 bar)
Material	Head: Aluminum alloy Immersion pipe: 304 SS
Operating Temp. (head)	-40°C ... +85°C
Protection Class	IP65

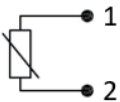
ELECTRICAL CONNECTION

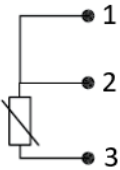
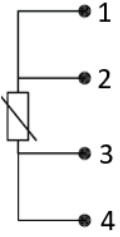
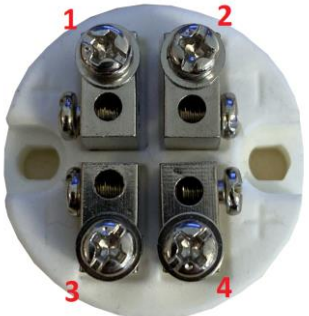
2-Wire		
3-Wire		
4-Wire		

ORDER CODE

1-Model

AST30

2- Temperature Range

Selectable from -195 to +650 °C (Ask for others)

3- Immersion Length

025: 25mm	150: 150mm	275: 275mm	400: 400mm
050: 50mm	175: 175mm	300: 300mm	425: 425mm
075: 75mm	200: 200mm	325: 325mm	450: 450mm
100: 100mm	225: 225mm	350: 350mm	475: 475mm
125: 125mm	250: 250mm	375: 375mm	500: 500mm

***We do not recommend using small immersion lengths for air or gas temperature measurements**, as the body absorbs heat due to the measurement probe being very close to the sensor body.

4- Immersion Pipe Diameter

8: 8mm
6: 6mm (only for pressures up to 0...200 bar)

5- Pressure Type

Y: High Pressure (For pressures higher than 200 bar)
D: Low Pressure (For pressures up to 0...200 bar)

6- Sensor Type

PT100
PT1000

7- Output Signal

RTD2 : 1xPT100 or 1xPT1000 (2-wire)
RTD3 : 1xPT100 or 1xPT1000 (3-wire)
RTD4 : 1xPT100 or 1xPT1000 (4-wire)

8- Process Connection

G1/4 : G1/4	NPT1/2 : NPT1/2
G1/2 : G1/2	M14 : M14x1
NPT1/4 : NPT1/4	M20 : M20X1,5

* Optional others

Sample order code: AST30 -40...+500 025 8Y PT100 RTD2 G1/4

BY PRODUCTS



EPA Series Measurement and Control Devices

[48x48mm model EPA 100](#)

[74x74mm model EPA 200](#)

[96x48mm model EPA 300](#)